

up-to-date electronics for lab and leisure

# ELEKTOR 4



June 1975 35p

# contents

selektor .....	606
tup-tun tester .....	608
This tester gives an instant check of the 'general health' of a transistor, as well as its compliance with the minimum TUP or TUN specification, by the very simple procedure of plugging it into test sockets and interpreting the messages from two light-emitting diodes. It is also possible to check diodes for excessive capacity or leakage.	
tup-tun-dug-dus .....	615
interference suppression in cars .....	616
Electrical interference generated by cars can be a source of annoyance, not only to the car occupants, but also to users of other electronic equipment external to the vehicle. This article discusses some of the more common causes of interference and their cure.	
thief suppression in cars .....	618
Thefts of cars, or accessories and/or other articles in them, are becoming more and more common. By the same token, anti-theft alarms for cars are becoming more and more of a necessity ....	
string sound .....	622
h-l logic tester .....	623
This is a TTL logic probe which, instead of the usual LED to indicate the logic states, uses a seven-segment Mintron or LED display to indicate 'H' for a high or '1' state and 'L' for a low or '0' state.	
tap preamp (2) .....	624
The first part of this article discussed an audio preamplifier and control unit operated entirely by TAP's and dealt with the design of the TAP and the electronic switching controlled by the TAP. This month's article deals with the application of these circuits to a complete touch-controlled preamp with the facilities already described.	
supplies for cars .....	632
In order to function effectively, electronic equipment used in cars must have an appropriate power supply, which must also suppress interference appearing on the battery voltage from the car electrical systems.	
mos-clock (2) .....	634
The mos-clock described in Elektor 1 has been extended with a crystal time base and an emergency supply. Both are mounted on one printed circuit board.	
what is cybernetics? — H. Ritz .....	637
beetle — Arbeitsgemeinschaft der Hauptschule Rossbach .....	638
Beetles, tortoises and the like have often served as models for cybernetic machines which must also have a reasonable appearance. The beetle described in this article can 'see, hear and feel' and reacts to information in the form of sounds and movements. The animal has a memory and can get tired.	
the moth — M. Keul, H. Löhr .....	644
This is a design for a simple cybernetic model, based on an electric toy car, that will be attracted towards a light source like a moth, negotiating obstacles in its path.	
micro-squeaker .....	645
quadro in practice .....	646
In response to an earlier article on quadrophony ('Quadro 1-2-3-4 ...', December 1974), we received many requests for the complete circuit of a quadrophony decoder. Nippon Columbia has now put such a design at our disposal, so that we can fulfil the wishes of many of our readers.	
elektor shorthand .....	660
missing link .....	660
sniff race control — E. Waschkowski .....	660

# tup tun tester

This tester gives an instant check of the 'general health' of a transistor, as well as its compliance with the minimum TUP or TUN specification, by the very simple procedure of plugging it into test sockets and interpreting the messages from two light-emitting diodes. It is also possible to check diodes for excessive capacity or leakage.

The principle of operation is simple and no preliminary calibration is needed — only the use of transistors and diodes known to be 'good' and resistors within the specified tolerance.

An astable multivibrator generates a square wave at a frequency of about 2 kHz, and this oscillation is turned on and off by another multivibrator at about 2 Hz. The collector-emitter path of the transistor under test (or the anode-cathode path of the diode) is connected in series with another transistor across the supply rails, and the intermittent 2 kHz square wave is fed in antiphase to the bases of each of the two transistors. Figure 1 shows a block diagram of the arrangement, from which a lot of information about the semiconductor under test can be deduced from the 'behaviour', voltage-wise, of the junction between the two semiconductors. This information can be displayed with the aid of only two light-emitting diodes (LEDs).

## Circuit Description

Figure 2 shows the complete circuit, which has been divided into three sections to avoid confusion. Transistors T5 and T6 in figure 2a form an astable multivibrator which runs at about 2 kHz. T2 and T3 form another multivibrator which runs at a much lower speed, about 2 Hz, and turns the 'fast' (2 kHz) oscillator on and off through transistor T4, which also supplies a 2 Hz switching waveform, via connection 'Q', to the display section T7 ... T9 and LEDs 'A' and 'B' (figure 2c). A similar 2 Hz switching waveform, in antiphase to the one which appears at 'Q', is supplied to the display section by T1 via 'P'. As will be seen later, these switching waveforms are needed to enable an unambiguous display to be obtained from two LEDs only.

An optional third LED (shown in the circuit as LED 'C') can be connected in series with the 680  $\Omega$  resistor R9 between 'Q' and supply negative. This will give a partial test of the tester itself by blinking in step with the slow oscillator

if this is functioning.

2 kHz square waves of equal amplitude and opposite polarity are produced intermittently at the collectors of T5 and T6. These two points, which drive the whole of the test circuitry, are marked 'X' and 'Y' respectively. When the fast oscillator is turned off, T5 is cut off and its collector ('X') is at its higher potential. The left-hand half of figure 2b is the section in which PNP-transistors are tested. It has been shown that 2 kHz square waves of equal amplitude and opposite polarity are being injected intermittently at 'X' and 'Y'.

## Display

Assume that a (good) PNP transistor is plugged in at the test point  $T_A$  in figure 2b. When the fast oscillator is off, 'X' is positive and 'Y' is negative. (The terms 'positive' and 'negative' are used to denote the higher and lower potentials taken up by various points in the circuit). Both the transistor T10 and the transistor  $T_A$  under test are therefore cut off, and the connection joining the collectors of T10 and  $T_A$  is floating. The diode D10 does not pass any current and the Darlingtons pair T11 and T12 is cut off. Figures 2b and 2c show that the collector of T12 is one of the points connected to the base of T9 (point A). When T12 is cut off, 'A' is positive and T9 is therefore also cut off. LED 'B', which is in the collector lead of T9, is therefore off, and the collector of T9 is negative.

To find what LED 'A' is doing, the other switching waveforms, derived from the slow oscillator via 'P' and 'Q', must now be examined. To switch the fast oscillator off, 'Q' must be negative; therefore 'P' is positive. T7 is connected to 'P', so T7 can conduct if its base receives a positive drive from the collector of T9 via R19.

In the situation now under consideration, however, the collector of T9 is negative and T7 does not pass current. T8 is also returned to the negative rail through LED 'A', but 'Q' is negative so LED 'A' stays off.

Recapping at this stage; with a good



transistor and when the fast oscillator is turned off, both LEDs are off. It has been seen that the three points which determine the LED display are 'A', 'P' and 'Q'. The basic relationship is as follows:

1. When 'P' is positive (i.e. the fast oscillator is turned off), LED 'A' will light up if the base of NPN transistor T7 is driven positively from the collector of T9.
2. When 'Q' is positive (i.e. the fast oscillator is turned on), LED 'A' will light up if the base of PNP transistor T8 is driven negatively from the collector of T9.
3. LED 'B' lights up when the collector of T9 is positive, irrespective of whether 'P' or 'Q' is positive.
4. When 'A' is negative, the collector of T9 is positive.

These relationships can be combined in a kind of truth table which will help in predicting the display for transistors or diodes in different states of health. They are also summarised, in a slightly different form, in figure 3a + b.

FAST OSCILLATOR TURNED	'A' SWINGS	LED A	LED B
Off	positive	Off	Off
Off	negative	On	On
On	positive	On	Off
On	negative	Off	On

What happens during the bursts when the fast oscillator is turned on?

'X' and 'Y' are being swung alternately positive and negative with opposite polarities at 2 kHz. When 'X' swings positive and 'Y' swings negative, the same reasoning which was applied to the situation when the fast oscillator is turned off will indicate that 'A' swings positive and LED 'B' is off. In this case, however, the fast oscillator is turned on ('Q' is therefore positive) and LED 'A' lights up.

When 'X' swings negative and 'Y' swings positive, it will be seen from figure 2b that both T10 and the transistor under test in T<sub>A</sub> are turned on. The emitter of T<sub>A</sub> is directly connected to supply positive, while the emitter of T10 is connected to supply negative through the 470 Ω resistor R28. If the current gain of T<sub>A</sub> is high enough, the potential at the collector of T<sub>A</sub> will move positively, D10 will conduct and the base of T11 will also move positively. (This will be discussed in more detail later.) The emitter of T12, the other transistor in the Darlington pair, is held by R30 and R31 at half the supply rail potential, so T12 is turned on; its collector potential (point 'A') swings negative and, as can be seen from the table, LED 'B' lights up and LED 'A' is off.

So the LED display while the fast oscillator is turned on and the transistor is a 'good' one is that 'A' and 'B' each come on during alternate half-cycles of the 2 kHz oscillation. Both LEDs therefore appear to be on during each 2 kHz burst, and it has already been seen that both are off while the fast oscillation is turned off.

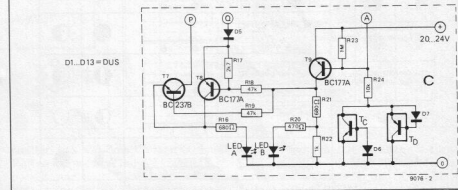
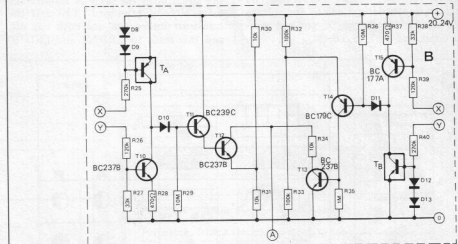
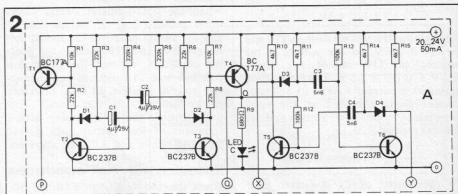
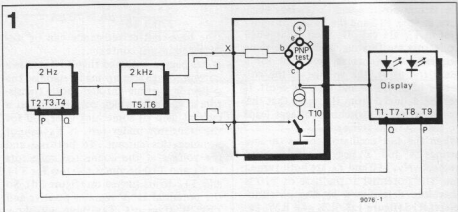

Figure 1. Block diagram of the arrangement for testing a PNP transistor. For clarity, the breakdown voltage test and the complementary test for an NPN transistor have been omitted.

Figure 2. Complete circuit of the TUP/TUN tester. Block A is the collector section, B contains the test bridges for NPN and PNP transistors and C shows the breakdown voltage testing and display sections.

The full display cycle for a 'good' transistor is that both LEDs blink on and off together (figure 3c). It will be seen later that this display occurs only with a transistor which is good according to all the criteria that are tested in socket T<sub>A</sub>.

### Transistor with low current gain (α')

When the fast oscillator is turned off,

'X' swings positive and 'Y' swings negative, so both T10 and the transistor under test in T<sub>A</sub> are cut off. Their commoned collectors are floating, and by the same sequence of events as described for a good transistor, the voltage at the collector of T9 is low and LED 'B' is off. It can be deduced from the table that this combination of switching voltages leads to LED 'A' also being off.

When the fast oscillator comes on and swings 'X' and 'Y' negative and positive respectively, T10 and T<sub>A</sub> are both turned on. The potential at the base of T10 is therefore determined by the potentiometer R15 (figure 1a), R26 and R27, i.e.

$$20 \times \frac{33}{4.7 + 120 + 33} = 4.2 \text{ V.}$$

The base-emitter voltage drop in T10 will be about 0.7 V, so the voltage at the emitter of T10 cannot rise above 4.2 V - 0.7 V = 3.5 V. T10 is therefore acting as a current source, its collector current being stabilised at the value determined by this latter voltage and the emitter resistor R28, i.e.

$$\frac{3.5 \times 1000}{470} \text{ mA} \approx 7.4 \text{ mA}$$

As the emitter of T<sub>A</sub> is directly connected to the positive supply rail, its base current is determined by the voltage (about 19 V) between 'X' and the positive rail, and by R25, i.e.

$$\frac{18 \times 10^6}{270 \times 10^3} \mu\text{A} \approx 70 \mu\text{A}$$

(the base-emitter resistance can be disregarded in this context).

It has been mentioned that T10 acts as a current source attempting to stabilise the collector current through both transistors at 7.4 mA, which corresponds to a current gain of something over 100 for the transistor under test. If T<sub>A</sub> cannot produce this current, T6 bottoms and the voltage at the connected collectors of T<sub>A</sub> and T10 becomes too low for T11 and T12 to be turned on (figure 3d). So the potential at 'A' remains positive and LED 'B' stays off. The table will show that LED 'A' comes on.

When the fast oscillator swings to its other polarity (i.e. 'X' swings positive and 'Y' swings negative) the linked collectors of T<sub>A</sub> and T10 revert to the floating condition, so that the Darlington pair T11 and T12 remains non-conductive and 'A' positive. LED 'B' therefore stays off and LED 'A' stays on.

Summarising: the LED display with a transistor of low current gain is that LED 'A' blinks and LED 'B' stays on.

### Transistor with high capacitances

When the fast oscillator is turned off, the situation is the same as in both the cases already examined: T10 and the transistor under test are both cut off, and this leads to LED 'A' and LED 'B'

both being off. When the fast oscillator comes on and swings 'X' negatively and 'Y' positively, both transistors are turned on, but if T<sub>A</sub> has high collector-to-base (C<sub>cb</sub>) and/or collector-to-emitter (C<sub>ce</sub>) capacitance, its response is delayed. The voltage rise at its collector is slowed down as these capacitances discharge, but the voltage will probably level off at its 'final' value before the end of the period in which T<sub>A</sub> is turned on, and when this happens LED 'B' comes on while LED 'A' stays off (figure 3e).

When, however, T<sub>A</sub> and T10 are once more turned off by the swings at 'X' and 'Y', the capacitances can recharge only through the Darlington pair T11 and T12 (which has, by definition, a high input impedance) and through the 10 MΩ resistor R29. The drop in potential at the collector of T<sub>A</sub>, as the capacitances recharge, is slower than it would be with a normal transistor, and if the capacitances are too large the potential will not fall far enough to turn T11 off (and therefore LED 'A' on and LED 'B' off) before the time when T<sub>A</sub> and T10 are turned on once again. So LED 'B' will stay on, and LED 'A' off, throughout each period when the fast oscillator is turned on.

With slightly smaller capacitances, LED 'A' may come on dimly if the slow recharge of excess capacitance only allows this LED to turn on for a small

## 3

a. Fast oscillator On/Off potential at (1)

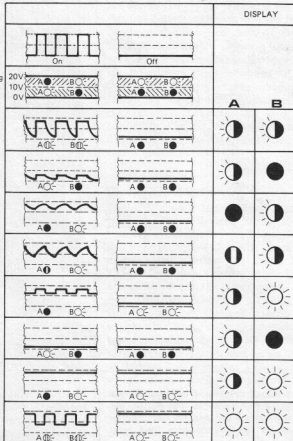

Figure 3. Summary of LED displays, based on the waveforms at the collector of the transistor under test.

Figure 4. Transistor testing chart, showing what the various displays signify. This chart is derived from figure 3.

Figure 5. Transistor (or diode) breakdown test chart.

Figure 6. The conduction test for diodes, in the 'PNP' test socket, is shown in figure 6A. The leakage test for diodes is shown in figure 6B.

Figure 7. Tests to test the tester.

DISPLAY		MEANING
LED A	LED B	
		Good transistor
		a. PNP/NPN reversed b. Leak > 1 μA c. C-B short d. C-E short
		a. a' < 100 b. B-E short
		C-B or C-E capacitance > 20p
		Leak > 10 μA + very low a' + large Ccb or Cce
		Ccb or Cce ≈ 20p
		Leak > 10 μA + a' < 50
		Impossible. If this happens something is wrong with the tester. Check the power supply!

	= On continuously		= Blinks
	= Blinks dimly		= Off

9076-4

DISPLAY		MEANING
LED A	LED B	
		Good (Breakdown voltage > 20 V)
		Fail (or connections reversed)

NPN	PNP	Diode

Key to display as for figure 4. 9076-5

part of each fast-oscillator cycle. Summarising again: the display for high capacitance is that LED 'B' blinks on and off while LED 'A' remains off or blinks dimly.

### Transistor with high leakage

A transistor with high leakage current tends to behave, from the tester's point of view, as though it were turned on all the time. In all the cases examined so far, no collector current flows in the transistor under test while the fast oscillator is turned off. If, however, there is a leakage current between collector and

emitter, this will flow through D10 and R29 to the negative rail even when 'X' is positive and both TA and T10 are supposed to be cut off. This leakage current develops a voltage across the 10 MΩ resistor R29, and therefore raises the potential at the base of T11.

It will be recalled that the emitter of T12 is held at half the supply voltage (i.e. at about 10 volts) by the potentiometer R30 and R31. So if the leakage current is a little more than 1 μA, it will build up a voltage sufficient to turn on T11 and T12 and thus light up LED 'A' and LED 'B' while the fast oscillator is

off. When the fast oscillator is turned on and the display transistors are switched through 'P' and 'Q', LED 'B' stays on but LED 'A' goes out (figure 3f). So with a transistor having a leakage current of 1 μA or more, LED 'B' stays on and LED 'A' flashes.

### Transistor with base and collector or emitter and collector short-circuited

A transistor with one of these faults 'looks like' one with high leakage (only more so). A current can flow from the positive rail through the emitter-base

DISPLAY		MEANING
LED A	LED B	
		Conducts satisfactorily
		Not conducting, i.e. open circuit or connections reversed

Key to display as for figure 4.		9076-6A
---------------------------------	--	---------

DISPLAY		MEANING
LED A	LED B	
		Blocks satisfactorily
		a. Leaks severely b. Shorted c. Connections reversed
		Leaks

Key to display as for figure 4		9076-6B
--------------------------------	--	---------

	TEST APPLIED	DISPLAY	
		LED A	LED B
1.	Nothing plugged into any test socket		
2.	Base and collector or emitter and collector sockets shorted in TA or TB		
3.	PNP or NPN transistor known to be good, correctly plugged into TA or TB as applicable		
4.	As previous test, but with a 22 pF capacitor connected from collector to base or emitter		
5.	Emitter and base leads of a PNP or NPN transistor known to be good connected to the collector and emitter sockets of TC or TD, whichever is appropriate; i.e. reverse-diode check of breakdown voltage testing section		

Key to display as for figure 4. 9076-7

8

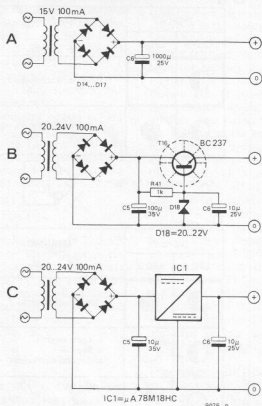

Figure 8. Alternative power supply arrangements, depending on the components one can obtain.

Figure 9. The p.c.b. and component layout for the TUP/TUN tester. Three alternative layouts are given, corresponding to the three power supply arrangements.

junction and the base-collector short in  $T_A$  (or directly through the emitter-collector short), through D10, and through the  $10\text{ M}\Omega$ -resistor R29. It has been shown that a leakage current as low as  $1\text{ }\mu\text{A}$  can turn on T11 and T12 and therefore make LED 'B' light up and LED 'A' go out while the fast oscillator is on. When the fast oscillator is off, LED 'A' lights up and 'B' stays on. So the display with base and collector or emitter and collector short-circuited is that LED 'B' stays on all the time, and LED 'A' blinks on and off (figure 3h).

### Transistor with base and emitter short-circuited

When the base and emitter are short-circuited, no 'normal' base current can flow, and therefore there is no collector current. So the transistor 'looks like' one with zero  $\alpha$ , and the LED display is the same: i.e. LED 'A' blinks and LED 'B' stays off (figure 3g).

### Combined leak and low current gain or combined leak and base-emitter short

While the fast oscillator is off, the display is the same as for a leaky transistor: both LED 'A' and LED 'B' are on. When the fast oscillator is on and is turning  $T_A$  and T10 off, the leakage current holds the collectors of  $T_A$  and T10 high enough in potential to turn on T11, resulting in LED 'A' being off and LED 'B' being on. When the fast oscillator turns  $T_A$  and T10 on, the low current gain of  $T_A$  allows T10 to 'overcome' both the leakage current and the

collector current (if any) in  $T_A$  and pull down the potential of the commoned collectors, whereupon LED 'A' comes on and LED 'B' goes off. This alternate lighting up of LED 'A' and LED 'B' is at the speed of the fast oscillator, and both LEDs stay on while the fast oscillator is turned off, so we have a display cycle in which both LEDs appear to be on continuously (figure 3i).

### Other combinations of Faults

It would not be a very profitable exercise to list the LED displays with all possible combinations of faults, but it can be said that only a transistor which is 'sound in wind and limb' according to all the test criteria will give the 'good transistor' display in both test sockets.

## PNP and NPN transistors

The foregoing descriptions apply to PNP transistors. They also hold good, mutatis mutandis, for NPN transistors plugged into test socket  $T_B$ , which appears on the right-hand side of figure 2b. The functions performed by T10, T11 and T12 and associated components for PNP transistors are performed by T13, T14 and T15 and associated components for NPN transistors. In this case, however, the transistors T13 and T14 which pass on a voltage drop at the anode of D11 are not a Darlington pair but a complementary PNP-NPN-pair.

If a transistor is plugged into the wrong test socket (PNP into an NPN socket or vice versa), the base-to-collector path becomes equivalent to a forward-connected diode, and the display is the same as for a transistor with a base-collector short. The transistor will not be damaged, and it is clearly a good thing, when one shows up unexpectedly as 'faulty', to check whether it has been plugged into the wrong holes!

## Breakdown Voltage Test

The sockets for this test are  $T_C$  and  $T_D$ , shown in figure 2c. The effective breakdown test voltage is about 20 V, and if a breakdown current flows the voltage at 'A' is pulled down continuously, resulting in LED 'A' blinking and LED 'B' staying on throughout the cycle. For a transistor which passes this test, LED 'A' blinks and LED 'B' stays off all the time (figure 5).

## Diode Tests

By plugging the anode and cathode leads of a diode into the emitter and collector sockets of the PNP test points (or the other way round with the NPN test points) it can be tested for forward conduction, leakage and breakdown voltage. When the fast oscillator is off, the junction of the diode cathode and the collector of T10 will be held positive by the conduction of the diode, and if the conduction is good enough, this junction will remain positive when T10 is turned on (through 'Y') by the fast oscillator. When T10 is turned off the junction will still be positive. This leads to a display cycle in which LED 'A' blinks and LED 'B' stays on continuously (figure 6).

When the diode is non-conducting, open-circuited or connected the wrong way round, the junction of T10 collector and the cathode (or anode) will remain negative throughout the oscillator cycle, giving a LED display in which 'A' blinks and 'B' remains off. When a diode is deliberately connected the wrong way round, this display gives an indication (if the diode is a good one) that it is blocking properly in the reverse direction. If a diode is short-circuited or is leaking severely, it will give the same display, when plugged in the wrong way round, as a good diode connected the correct way round. It is just possible, however, that it is a good diode plugged

7 to  
pod,  
ators  
e ap-  
e 2b.  
T11  
s for  
T13,  
ents  
ow-  
hich  
e of  
ut a

rong  
et or  
h be-  
ected  
s for  
ort.  
and  
one  
to  
into

Tp.  
reak-  
if a  
tage  
asly,  
and  
the  
this  
ays

eads  
actor  
the  
test  
con-  
tage.  
the  
the  
ative  
nd if  
this  
T10  
fast  
the  
eads  
D'A'  
ous-

pen-  
way  
ector  
main  
ycle,  
links  
le is  
way  
ation  
it is  
irect-  
or is  
ame  
way  
ible.  
egged

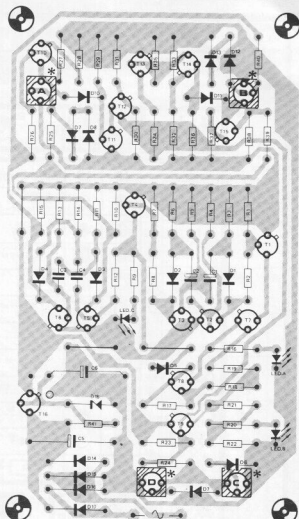
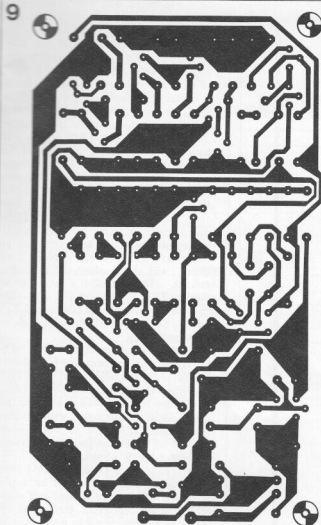

Stabilised supply with discrete components

Tr = 20 V/100 mA  
R41 = 1 k  
C5 = 100  $\mu$ /35 V

C6 = 10  $\mu$ /35 V  
T16 = BC237B  
D18 = 20 V Zener

#### Parts list

##### Resistors:

R1, R7, R24, R30, R31, R34 = 10 k  
R2, R3, R6, R8 = 22 k  
R4, R5 = 220 k  
R9 (if used), R16, R21 = 680  $\Omega$   
R10, R11, R14, R15 = 4k7  
R12, R13, R32, R33 = 100 k  
R17 = 2k7  
R18, R19 = 47 k  
R22 = 1 k  
R25, R40 = 270 k  
R26 = 120 k  
R27, R38 = 33 k  
R28, R37, R20 = 470  $\Omega$   
R29, R36 = 10 M  
R23, R35 = 1 M  
R39 = 120 k  
R40 = 270 k

##### Capacitors:

C1, C2 = 4 $\mu$ 7  
C3, C4 = 5n6

##### Semiconductors:

T1, T4, T8, T9, T15 = BC307B or equ.  
T2, T3, T5, T6, T7, T10, T12, T13, T16 = BC237B or equ.  
T11 = BC239C or equ.  
T14 = BC179C or equ.  
D1 ... D17 = BAX13, BY126, BY127, 1N4002, or other general-purpose silicon diodes  
2 x LEDs

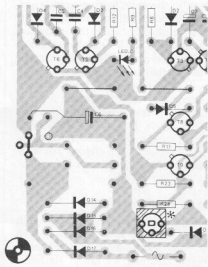

Unstabilised supply  
Tr = 18 V/100 mA  
C6 = 1000  $\mu$ /25 V

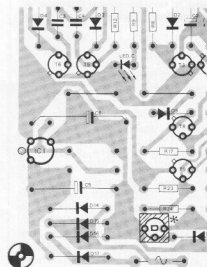

Stabilised supply with IC  
Tr = 20 V/100 mA  
C5 = 100  $\mu$ /35 V  
C6 = 10  $\mu$ /35 V  
IC =  $\mu$ A78M18HC or equ.



10

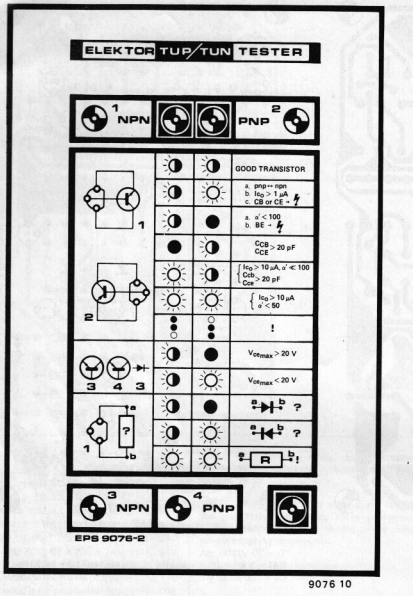

Figure 10. Front panel design for the tester. This panel is available via the Elektor print service, with black lettering on an aluminium background.

in the correct way round, i.e. that one has mistakenly connected it this way instead of reversing the connections. So it is important to make tests in both polarities if ambiguities are to be avoided.

If a diode which leaks moderately is plugged in the wrong way round, the leakage current may be enough to hold the anode of D10 positive while T10 is turned off, but not while T10 is turned on. This will give a display in which both LEDs appear to be on continuously — the same as for a transistor which is both leaky and low in current gain.

#### General

Figure 3 summarises the LED indications when the fast oscillator is on or off, and for different potentials at the anode of D10 in the main PNP testing section. The difference between this figure and table 1 is that the table is based on the

fast oscillator and point 'A', which is common to the main testing circuits and to the breakdown voltage testing circuit. The relationship between the potential at the anode of D10 and the potential at 'A' when the main PNP testing section is in use is that a high potential at the anode of D10 produces a low potential at 'A' and vice versa. Figures 4, 5 and 6 summarise the meanings of the possible LED indications for various tests. Figure 4 is, of course, derived from figure 3. The front panel design (figure 10) summarises all three figures.

#### Construction and testing

Unless one has access to an independent means of testing the transistors and diodes, these should be ones which carry the manufacturers' warranty. Resistors should have 5% tolerance.

Figure 9 shows the p.c. board and the component layout for the complete tester (with the exception of the mains transformer). It should be noted that the emitter and collector connections to the test sockets appear to be interchanged, but when the sockets are mounted on the copper side of the board

the connections will be correct. This facilitates the mounting of the board flush under the top panel, without the other components getting in the way. As it is not possible to give meaningful voltage or current test values for individual transistors, which might help to localise mistakes or faults, the construction should be checked very carefully. Even if one does not intend to use the optional LED 'C', one of the LEDs which will ultimately serve as 'A' or 'B' can be 'borrowed' at the constructional stage to serve temporarily as 'C' and thus give a check whether the slow oscillator (T2 and T3) and also T4 is working. The actual value of the nominally 680  $\Omega$  resistor in series with 'C' is not critical. If the temporary 'C' is seen to blink at about the right rate, test number 1 of figure 7 will show whether T8 is also working. Test number 2 will show whether T7, T9, T11 and T12 are working if the short is put into test socket T<sub>A</sub>, and T7, T9, T13 and T14 with the short in test socket T<sub>B</sub>.

To check the complete PNP and NPN testing sections, including the breakdown voltage test, one will need spare PNP and NPN transistors known to be sound, in addition to those used in building the tester. Only a transistor with normal current gain, or with a particular combination of faults, can produce a display in which LED 'B' blinks.

Once the two good transistors have been seen to give the display for test number 3 of figure 7, the more refined test number 4, which simulates the effect of excessive capacitance, can be applied. A 22 pF capacitor should be enough to make LED 'A' black out altogether, but it may be of interest to experiment with different lower capacitor values to find what value of capacitor is just low enough to allow the waveform at the junction of T<sub>A</sub> and T10 to extend below the critical level (about 10 V) and cause LED 'A' to blink dimly, as shown in figure 3e<sub>2</sub>.

The emitter-base junction of a transistor forms a diode with a reverse breakdown voltage of about 5 V, so one of the transistors used in the foregoing checks can also be used to check the breakdown voltage testing section (figure 7; number 5). One must make sure that it is connected the right (or is it the wrong?) way round.

#### Power Supplies

Three different possibilities are offered for a mains power supply unit (figure 8): a simple unbalanced unit, a stabilised unit with the stabilisation circuit built up from three discrete components, or a stabilised unit using an IC. The unbalanced unit uses a transformer with an 18 V secondary — which may sometimes be difficult to obtain — and a 1000  $\mu$  capacitor. If either of the stabilisation circuits is used, the capacitor can be much smaller. The 20 V transformer used in these circuits should be more readily obtainable.

The transistor or IC should have a heat-sink.

# TUP TUN DUG DUS

Wherever possible in Elektor circuits, transistors and diodes are simply marked 'TUP' (Transistor, Universal PNP), 'TUN' (Transistor, Universal NPN), 'DUG' (Diode, Universal Germanium) or 'DUS' (Diode, Universal Silicon). This indicates that a large group of similar devices can be used, provided they meet the minimum specifications listed above.

For further information, see the article 'TUP-TUN-DUG-DUS' in Elektor 1, p. 9.

	type	$U_{ce0}$ max	$I_c$ max	$h_{fe}$ min.	$P_{tot}$ max	$f_T$ min.
TUN	NPN	20 V	100 mA	100	100 mW	100 MHz
	PNP	20 V	100 mA	100	100 mW	100 MHz

Table 1a. Minimum specifications for TUP and TUN.

Table 1b. Minimum specifications for DUS and DUG.

	type	$U_R$ max	$I_F$ max	$I_R$ max	$P_{tot}$ max	$C_D$ max
DUS	Si	25 V	100 mA	1 $\mu$ A	250 mW	5 pF
	Ge	20 V	35 mA	100 $\mu$ A	250 mW	10 pF

Table 2. Various transistor types that meet the TUP specifications.

TUN		
BC 107	BC 208	BC 384
BC 108	BC 209	BC 407
BC 109	BC 237	BC 408
BC 147	BC 238	BC 409
BC 148	BC 239	BC 413
BC 149	BC 317	BC 414
BC 171	BC 318	BC 547
BC 172	BC 319	BC 548
BC 173	BC 347	BC 549
BC 182	BC 348	BC 582
BC 183	BC 349	BC 583
BC 184	BC 382	BC 584
BC 207	BC 383	

Table 3. Various transistor types that meet the TUP specifications.

TUP		
BC 157	BC 253	BC 352
BC 158	BC 261	BC 415
BC 177	BC 262	BC 416
BC 178	BC 263	BC 417
BC 204	BC 307	BC 418
BC 205	BC 308	BC 419
BC 206	BC 309	BC 512
BC 212	BC 320	BC 513
BC 213	BC 321	BC 514
BC 214	BC 322	BC 557
BC 251	BC 350	BC 558
BC 252	BC 351	BC 559

Table 4. Various diodes that meet the DUS or DUG specifications.

DUS	DUG	
BA 127	BA 318	OA 85
BA 217	BAX 13	OA 91
BA 218	BAY 61	OA 95
BA 221	1N914	AA 116
BA 222	1N4148	
BA 317		

Table 5. Minimum specifications for the BC107, -108, -109 and BC177, -178, -179 families (according to the Pro-Electron standard). Note that the BC179 does not necessarily meet the TUP specification ( $I_{c,max} = 50$  mA).

	NPN	PNP
		BC 107 BC 108 BC 109
$V_{ce0}$ max	45 V 20 V 20 V	45 V 25 V 20 V
$V_{eb0}$ max	6 V 5 V 5 V	5 V 5 V 5 V
$I_c$ max	100 mA 100 mA 100 mA	100 mA 100 mA 50 mA
$P_{tot}$ max	300 mW 300 mW 300 mW	300 mW 300 mW 300 mW
$f_T$ min.	150 MHz 150 MHz 150 MHz	130 MHz 130 MHz 130 MHz
F max	10 dB 10 dB 4 dB	10 dB 10 dB 4 dB

The letters after the type number denote the current gain:

- A:  $\alpha'$  ( $\beta$ ,  $h_{fe}$ ) = 125-260  
 B:  $\alpha'$  = 240-500  
 C:  $\alpha'$  = 450-900.

Table 6. Various equivalents for the BC107, -108, ... families. The data are those given by the Pro-Electron standard; individual manufacturers will sometimes give better specifications for their own products.

NPN	PNP	Case	Remarks
BC 107 BC 108 BC 109	BC 177 BC 178 BC 179		
BC 147 BC 148 BC 149	BC 157 BC 158 BC 159		$P_{max} = 250$ mW
BC 207 BC 208 BC 209	BC 204 BC 205 BC 206		
BC 237 BC 238 BC 239	BC 307 BC 308 BC 309		
BC 317 BC 318 BC 319	BC 320 BC 321 BC 322		$I_{c,max} = 150$ mA
BC 347 BC 348 BC 349	BC 350 BC 351 BC 352		
BC 407 BC 408 BC 409	BC 417 BC 418 BC 419		$P_{max} = 250$ mW
BC 547 BC 548 BC 549	BC 557 BC 558 BC 559		$P_{max} = 500$ mW
BC 167 BC 168 BC 169	BC 257 BC 258 BC 259		169/259 $I_{c,max} = 50$ mA
BC 171 BC 172 BC 173	BC 251 BC 252 BC 253		251 ... 253 low noise
BC 182 BC 183 BC 184	BC 212 BC 213 BC 214		$I_{c,max} = 200$ mA
BC 582 BC 583 BC 584	BC 512 BC 513 BC 514		$I_{c,max} = 200$ mA
BC 414 BC 414 BC 414	BC 416 BC 416 BC 416		low noise
BC 413 BC 413	BC 415 BC 415		low noise
BC 382 BC 383 BC 384			
BC 437 BC 438 BC 439			$P_{max} = 220$ mW
BC 467 BC 468 BC 469			$P_{max} = 220$ mW
	BC 261 BC 262 BC 263		low noise

# TUP TUN DUG DUS

# interference suppression in cars

Electrical interference generated by cars can be a source of annoyance, not only to the car occupants, but also to users of other electronic equipment external to the vehicle. This article discusses some of the more common causes of interference and their cure.

Anyone who has installed a car radio and then discovered that the programme is drowned out by odd buzzes, pops and crackles will know how difficult it is to trace and suppress interference. Commercially available 'do-it-yourself' suppression kits often do not effect a cure, because the interference is not dealt with at source.

Interference in cars on radio and T.V. bands is caused by high-frequency energy, usually produced by arcing contacts, but also by discharge of static electricity. The interference may be continual, for example that originating from the ignition circuitry, or it may be transient, such as interference occurring when light switches or brake lights are operated. Windscreen wiper motors can also generate substantial interference when they are running.

Interference may be divided into two groups:

1. External Interference.
2. Internal Interference.

External interference affects not only electronic equipment in the car but also radios and televisions in the vicinity. Internal interference is usually restricted to bad reception on the car radio.

The principal sources of interference in a car are as follows:

ignition system  
dynamo and regulator  
screenwiper motor  
electric fan (if fitted)  
heater fan motor  
petrol gauge  
brake light switch  
light switches  
starter motor  
starter relay and switch  
trafficator flasher unit  
relays  
ignition switch

Some of these, such as the ignition switch and light switches, cause interference of a very transient nature and are probably not worth bothering with.

The ignition system is the most powerful source of interference and will be dealt with first. Interference can be suppressed at various points in the ignition circuit. Figure 1 shows a typical arrangement of the high-tension side of an ignition system. Screened plug caps provide a good degree of suppression. The screening makes contact with the plug base and covers the porcelain insulator. A typical screened plug cap is shown in

figure 2. These are available from auto electricians. Plug caps with a built-in suppression resistor are also effective, or alternatively 'carbon-string' H.T. leads may be used, though the mechanical reliability of these is questionable. The distributor may already have suppression incorporated, but if not, suppressor caps may be fitted to the distributor cover. These should have a resistance of about 1 k. Alternatively, in-line suppressors may be fitted in the plug leads near the distributor.

If a radiotelephone is installed in a car, an extreme degree of ignition suppression may be necessary in the form of screened cables for all H.T. leads and connections to the coil. Under normal conditions the coil itself may be suppressed by connecting a capacitor of about  $3\mu$  400 V between the SW (ignition Switch) terminal of the coil and earth. Figure 3 shows how this is done.

The second important source of interference is the dynamo/regulator system of the car. Dynamos generally have two connections, one to the armature (via the brushes and commutator), which is the output terminal of the dynamo, and one to the field winding, the current

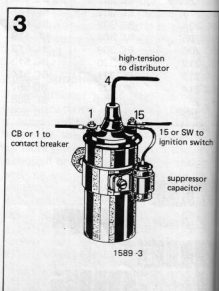
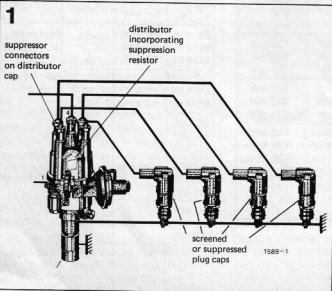

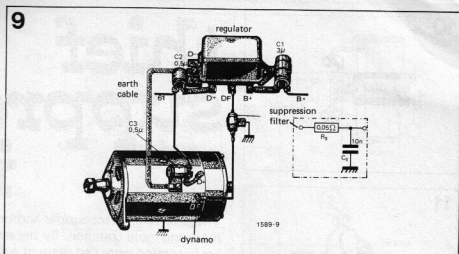
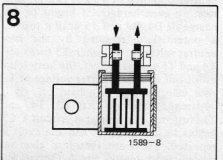
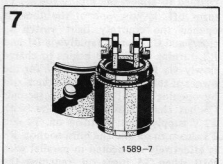
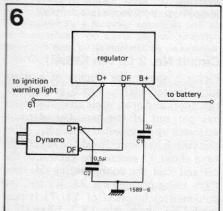
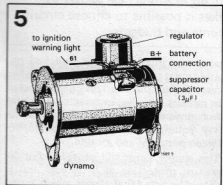
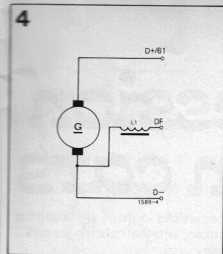

Figure 1. Diagram of the high tension side of a typical car ignition system, showing places to incorporate suppression.

Figure 2. Cut-away drawing of a typical screened plug cap.

Figure 3. Ignition coil showing where to connect suppressor capacitor. Numbers on various terminals are DIN standard codes for these terminals.

Figure 4. Connections to a dynamo. Usually only the armature and field connections are brought out to terminals and the common terminal is earthed to the frame of the dynamo. Again DIN standard codings are used for the terminals.

Figure 5. A low-power dynamo with an integral regulator showing connection of suppressor capacitor.

Figure 6. Circuit showing suppressor connections for dynamo with integral regulator. An  $0.5 \mu\text{F}$  capacitor may be connected from the armature terminal if necessary, or if this is not directly accessible, from the ignition warning light terminal.

Figure 7. General appearance of a non-coaxial feedthrough capacitor.

Figure 8. Internal construction of a non-coaxial feedthrough capacitor.

Figure 9. Suppression of dynamo with remotely-mounted voltage regulator.

through which controls the output voltage. The commonest type of electromechanical voltage/current regulator has three relays that respond to dynamo output voltage and charging current and control these parameters. The contacts of these relays can generate interference, as can the dynamo commutator/brush contact.

Small cars with dynamos of less than 300 W output often have the regulator integral with the dynamo. In that case the terminals of the dynamo are not directly accessible and there are only two connections to the voltage regulator. One is the output terminal to the battery

and the other is the connection to the ignition warning light. The battery terminal may be decoupled with a  $3 \mu\text{F}$  capacitor and the indicator terminal with a  $0.5 \mu\text{F}$  capacitor (no larger!) as shown in figures 5 and 6.

For larger dynamos with remotely-mounted regulator, suppression may be connected as shown in figure 9. For improved suppression, capacitors of the non-coaxial feed-through type may be used. These have a lower series self-inductance than the normal type of suppressor capacitor as the current flows in through one terminal virtually right up to the capacitor plates, and out of the other terminal. Any lead inductance is in series with the current-carrying input and output cables. With the normal type of capacitor a length of (inductive) cable connects it to the terminal it is supposed to suppress, which increases its impedance to high frequencies, when it should have a low impedance to shunt them to earth. A non-coaxial feedthrough capacitor is shown in figures 7 and 8. If capacitors on the three regulator terminals and on the dynamo armature terminal do not provide sufficient suppression a suppressor filter can be connected in the field cable as shown in figure 9. This can be home-made from a 10 n low-inductance capacitor and a 0.05 ohm resistor wound from  $2\frac{1}{2}$  m of 19 SWG copper wire.

## Electric Motors

All electric motors in a car (windscreen wiper, heater, electric cooling fan) are potential sources of interference. They can usually be suppressed by a  $3 \mu\text{F}$  capacitor on the supply terminal. If this is not sufficient then non-coaxial feedthrough capacitors of 0.5 to  $2.5 \mu\text{F}$  must be used.

## Electrostatic Charges

If annoying crackles and pops are heard from the car radio when driving on dry roads, this may be due to electrostatic charges building up on the tyres because of friction between the tyres and the road. Since the grease film in the wheel bearings forms an efficient insulator such charges cannot leak away to chassis except when they achieve a high

10

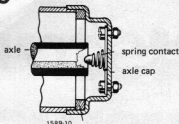

11

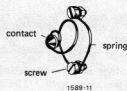

Figure 10. Making good contact between the wheel hub and the axle by means of a spring contact mounted in the axle cap.

Figure 11. Construction of spring contact.

enough voltage to flash over, hence the crackles and pops. A solution to this problem is to make a good electrical contact between the axle hub cap mounted in the centre of the hub (not the decorative hub cap) and the axle. See figures 10 and 11.

### Fuel Gauge

The fuel gauge potentiometer may cause interference, as may other contacts such as the trafficator flasher unit. Such interference can usually be cured by a capacitor of about  $3 \mu$  between the offending contact and earth.

### Conclusions

The ignition system is the principal source of interference and should be tackled first. To avoid possible unnecessary expense the results of suppressing the ignition system should be assessed before proceeding with further measures. With a good car radio suppression of the ignition system will usually be sufficient, but if a cheap car radio with poor selectivity and sensitivity is employed, additional suppression may be necessary. For car radios the adage 'you get what you pay for' is certainly true, and a cheap radio may prove to be more expensive if a large degree of suppression has to be used. This is particularly true if the radio has an FM band as well as long and medium wave bands, as cheap radios often need a high degree of suppression if FM reception is to be satisfactory. A more expensive car radio is usually a sound investment, especially as a car radio cannot be tested in the shop under the actual conditions in which it will be used.

Cars which are fitted with radiotelephone equipment generally need very effective suppression and such installations are best left to specialists in the field. ■

# thief suppression in cars

Thefts of cars, or accessories and/or other articles in them, are becoming more and more common. By the same token, anti-theft alarms for cars are becoming more and more of a necessity . . .

Each of the four different designs described in this article allows for variations on the basic concept; this makes it possible to choose circuits that will suit a large variety of requirements and budgets.

Each year an increasing number of cars are stolen. The majority of them are quickly recovered, but at best they have been abandoned on running out of petrol, and often they are a total write-off, with everything of value removed. Thefts of articles from cars are still more common, especially now that expensive in-car entertainment systems are so popular. When compared with the possible loss of property and/or no-claims bonus, the cost of installing a burglar alarm is negligible, and a number of designs are presented here, which vary in cost from about 10 p to £10, and give varying degrees of protection. Even with an alarm installed, however, do not ignore the simple precautions advised by the police. Lock all valuables in the boot, and make sure that all doors and windows are securely fastened.

### Circuit No. 1

The simplest of the burglar alarms can be constructed from components that most enthusiasts will have in their junk box. It makes use of the door courtesy light switches and the horn relay, and the only additional components required are three diodes and a hidden switch to activate and de-activate the alarm. However, one door of the car is left unprotected.

The circuit operates as follows:

$S_1$  and  $S_2$  are the courtesy light switches. When the hidden switch  $S_3$  is closed, opening the door protected by  $S_2$  causes the horn relay to operate via  $S_3$ , D2 and  $S_2$ . When the horn relay contacts close the horn sounds and the cathode of D3 is grounded via the relay contacts. This latches the horn relay via  $S_3$  and its own contacts. The horn will continue to sound even if the door is closed, unless  $S_3$  is opened. The door containing  $S_1$  is, of course, not protected, as when  $S_1$  is closed D1 is reverse biased and only the interior light operates.

When the alarm is not armed ( $S_3$  open), D2 prevents the interior light from lighting when the horn button is pressed and D3 prevents the horn from sounding

when the interior light is switched on. Additional courtesy light switches (in the case of a four-door car) may be connected in parallel with  $S_2$ , and switches to protect glove compartment and other ancillary equipment may be connected between point 'A' and ground.

This simple alarm will provide a fair degree of protection at little cost, but it should be noted that alarms which sound indefinitely after being triggered are illegal in some European countries.

### Circuit No. 2 (J. van Kessel)

Figure 2 shows the circuit of a more sophisticated alarm, which protects all the doors and arms itself after the driver has got out of the car. The alarm is activated by a concealed switch  $S_1$ . After this switch has been closed the occupants have about 15 seconds to get out of the car and shut the doors. During this time C1 is being charged via R1, R2 and the base-emitter junction of T1. T1 is thus turned on, shorting out C2. When C1 is charged to almost the supply voltage T1 turns off. If now one of the doors is opened the courtesy light switch  $S_2$  closes and C2 charges rapidly via D1 and R3, turning on T2. C3 begins to charge slowly via R5, which gives time for the owner of the car to de-activate the alarm by opening  $S_1$ . After about 15 seconds C3 has charged to about 8 volts (with 12 V supply) and T3 turns on. T4 and T5 also turn on and the horn sounds. R8 is effectively connected in parallel with R10 when T5 turns on, reducing the emitter potential of T3 and causing it to turn on even harder. C3 begins to discharge via D4, R7 and T5 until it reaches a potential determined by the new emitter voltage of T3, when T3 turns off. T4 and T5 are turned off, the horn relay drops out and the emitter voltage of T3 rises causing it to turn hard off. (It is apparent, therefore, that T3, T4, and T5 function as a trigger circuit.) C3 begins to charge again and the cycle is repeated. The horn therefore gives repeated short blasts, which (hopefully)

Figure consisting of door condition parallel and glove earth.

Figure The door L is the

Figure be triggered door delay conce

Figure the alarm AND-glove

3

4

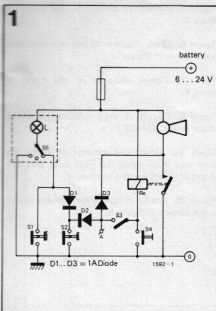
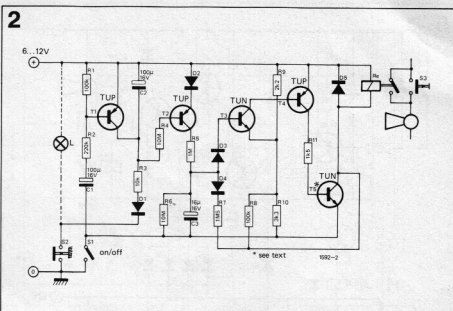

Figure 1. Circuit of the simplest burglar alarm consisting of three diodes and a switch. The door containing  $S_1$  is not protected. Additional door switches should be wired in parallel with  $S_2$ , other switches such as boot and glove compartment between point 'A' and earth.

Figure 2. A more sophisticated alarm circuit. The door switches are wired in parallel with  $S_2$ . L is the interior light.

Figure 3. Block diagram of an alarm that can be triggered by a trembler switch as well as door switches. This alarm has no 're-entry' delay and must be de-activated by an external concealed switch.

Figure 4. The number of points protected by the alarm may be extended using a diode AND-gate for switches on boot lid, bonnet, glove compartment etc.



will attract more attention than a continuous note.

Even if the car door is subsequently closed it will take a long time for C2 to discharge via R4 into the base of T2. T5 should have a sufficiently high collector current rating for the relay used. If the original car horn relay is used then a power transistor may be needed, and R11 must be reduced to provide sufficient base current.

To use the alarm with a positive earth car it is necessary to substitute all the transistors by their complements (i.e. TUP for TUN) and to reverse the polarity of all electrolytic capacitors and diodes.

**Circuit No. 3 (H. Bernstein)**

A different approach is adopted in the

circuit whose block diagram is given in figure 3. This circuit has a switch-on delay to enable the driver to leave the car, but the alarm sounds immediately one of the doors is opened, thus reducing the possibility of a thief breaking into the car and stealing some article before the alarm goes off. This does mean, of course, that the alarm must be deactivated before the driver enters the car. This may be done by a concealed switch outside the car, or by a reed switch mounted in the windscreen and operated by a magnet carried on the key-ring. This alarm also has a circuit operated by a trembler switch which will operate if the car is rocked or shaken. This will help prevent the theft of such articles as mirrors, fog and spot lamps, and will also operate if an attempt is made to force a door or window. Such switches can be bought, or can easily be home made. Figure 4 shows the method of connecting switches. S represents the door courtesy light switches. Additional switches may be wired as shown in dotted lines. The diodes form an AND gate and isolate the switches from one another so that they do not interact. A diode is only required in series with each switch that performs some additional function as well as being connected to the alarm system. Thus, when there is a switch in the boot that operates the boot interior light, then a diode is required in series with this to prevent the light being switched on by the other switches. Where a switch is installed solely for the purpose of the alarm (e.g. in the glove compartment) then no diode is required.

The circuit of the complete alarm is given in figure 5. It operates as follows: Before leaving the car  $S_1$  is opened. This initiates the switch-on delay as C1 charges. T1 turns off, which turns off T2 and T3. The alarm is now set. If one of the switches connected to points a-d is closed, C2 is rapidly discharged via R6 and T4 turns on, sounding the horn. The alarm will continue for up to two minutes even if the switch is opened, as C2 charges again.

A separate circuit is included for the

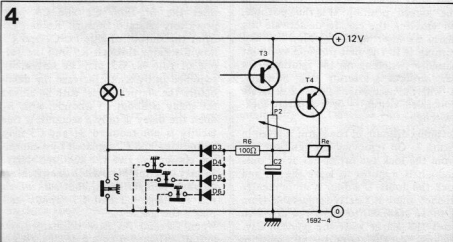
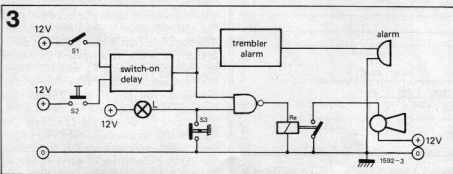

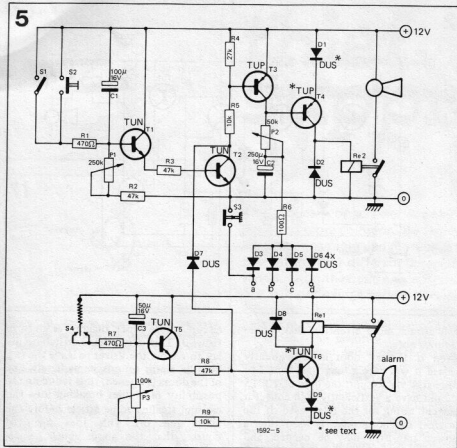

Figure 5. Complete circuit of the alarm of figure 3.

Figure 6. Block diagram of the most sophisticated alarm in the series.

Figure 7. Timing diagram of the alarm of figure 6.

Figure 8. Circuit of the sophisticated alarm, which uses COSMOS IC's.

Figure 8a. Alternative method of wiring the horn and horn relay, for cars with one side of the horn connected to chassis.

Figure 9. Timing diagram for various points in the circuit of figure 8.

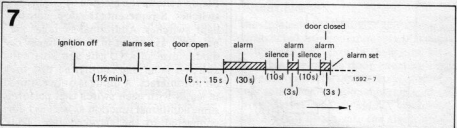
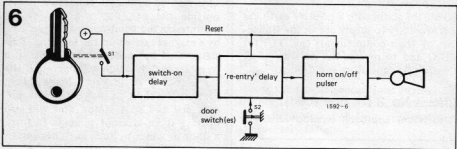

trembler alarm. T2 grounds the base of T6 via D7 until after the switch-on delay. If the trembler switch S4 subsequently closes momentarily, C3 rapidly discharges via R7, turning on T5. This turns on T6 and the alarm sounds until C3 is recharged, when T5 turns off. Re-entering the car is accomplished by momentarily closing the concealed switch S2, which discharges C1 and initiates the switch-on delay so that the driver can enter the car and close S1, which de-activates the alarm.

#### Circuit No. 4

A block diagram of the most sophisticated alarm in this series is given in figure 6. In many modern cars with a steering lock there is no need to have a concealed reset switch as a position is

often available on the ignition switch that only opens when the switch is in the 'locked' position. It is thus possible, on entering the car, to de-activate the alarm by inserting the ignition key and turning it to the first position (without actually switching on the ignition). On cars without a steering lock, however, it will be necessary to use a separate concealed switch — or a separate lock-switch.

A timing diagram of the alarm is given in figure 7. On removing the ignition key from the lock the driver has about one-and-a-half minutes to leave the car and lock the doors. If a door is subsequently opened there is a delay (adjustable from 5 to 15 seconds) to allow the driver to reset the alarm with the ignition key. Failing this, the alarm operates and the

horn will sound continuously for 30 seconds. After this there is ten seconds silence, then short three second blasts with ten seconds silence in between until the alarm is reset or the door is closed. The complete circuit of the alarm is given in figure 8. When S1 is opened C1 begins to discharge through R1 and R2. When the voltage on C1 falls below the threshold voltage of gate 1 and 2 is set. This holds the input (pin 13) of gate 4a high, which means that when one of the door switches (represented by S2) closes, the flip-flop consisting of gates 3a and 4a is set. The alarm is triggered, and even closing the door (opening S2) will not reset the flip-flop. C2 and C3 were previously charged through R6 and D3 from the output of gate 1a. C2 and C3 now discharge through R5 into the output of gate 4a. C3 may be optionally switched in by S3 to increase the delay before the alarm sounds. With S3 closed the delay is about 15 seconds; with S3 open the delay is only 5 seconds. If this facility is not required S3 and C3 may be omitted and C2 replaced by a capacitor chosen to give the required delay. S4 may be a trembler switch or switch(es) on glove compartment, boot etc., which will discharge C2 and C3 rapidly and trigger the alarm. When C2 and C3 have discharged the output of gate 2b goes high. This takes

pin 6  
input  
low,  
the 1  
R15  
gate  
charg  
const  
of th  
30 se  
When  
thres  
of th  
gate  
of 1  
switc  
D7, I  
slowl  
and  
'off'  
on(s)  
thres  
goes  
charg  
time  
'on'  
on(s)  
After  
low,  
R12  
Gates  
multi  
produ  
vals.  
switc

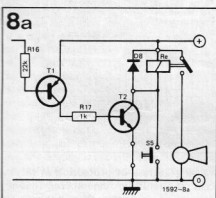
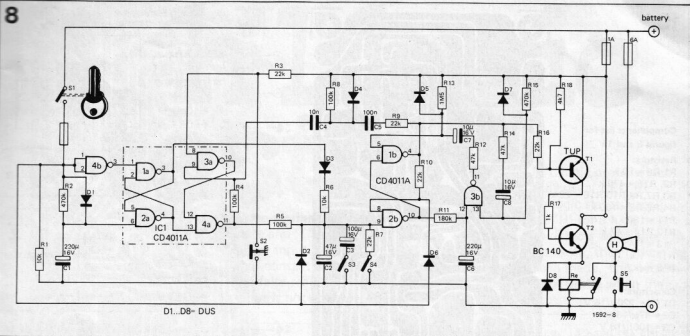

pin 6 of gate 1b high. Since the other input is held high by R13 the output goes low, turning on T1 and T2 and sounding the horn. C8 charges through R14 and R15 in about 3 seconds, taking pin 13 of gate 3b high. Meanwhile C6 slowly charges through R11 and it is this time constant that determines the duration of the initial blast of the horn (about 30 seconds).

When the voltage on C6 exceeds the threshold voltage of gate 3b the output of this gate goes low, grounding pin 5 of gate 1b through C7 and R12. The output of 1b thus goes high and the horn switches off. C8 now discharges through D7, R14 and the output of gate 1b. C7 slowly charges through R13 and R12, and this time constant determines the 'off' period of the horn (about 10 seconds). When C7 has charged to the threshold voltage of gate 1b the output goes low and the horn again sounds. C8 charges through R14 and R15, and this time constant determines the subsequent 'on' periods of the horn (about 3 seconds).

After this period the output of 3b goes low, grounding pin 5 of gate 1b through R12 and C7, and the whole cycle repeats. Gates 1b and 3b thus form an asymmetric multivibrator which causes the horn to produce short blasts at 10 second intervals. In addition, each time the horn is switched off a differentiating network

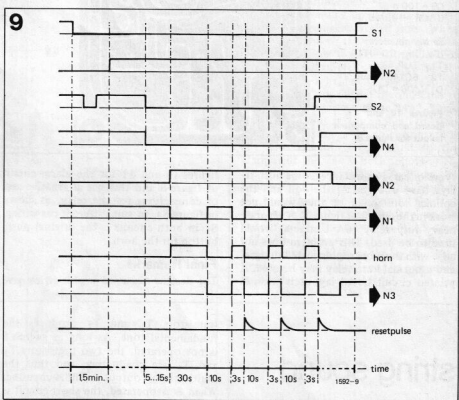

consisting of R8, R9, C4 and C5 feeds a reset pulse to pin 9 of gate 3a, so that if the doors are closed during the horn 'off' period, the horn will not sound again and the alarm will be re-set.

The disadvantage of this alarm circuit is that it cannot easily be adapted for positive earth cars. On the other hand, it has the advantage that it is insensitive to spurious pulses due to the high noise immunity of COSMOS. The circuit will operate over a wide range of supply voltages without modification (4 to 14 volts), with almost the same delays.

#### Installation of the alarm

To ensure reliable operation the alarm should be mounted where it cannot be disabled by a thief, but not inside the engine compartment, which gets rather

hot for COSMOS. Wiring should be concealed or made as inconspicuous as possible, especially wiring into the engine compartment if the car does not have a bonnet lock. In this case it is also wise to install an alarm switch in the bonnet lid, as otherwise the alarm could be disabled simply by disconnecting the battery. Another (somewhat expensive) possibility would be to power the alarm from a separate battery locked in the boot. Wiring from the battery to the alarm should, of course, be direct, not via the ignition switch, and the simplest way is to run cables from the battery side of the fuse box with in-line fuse holders in them.

When constructing any of these alarms it should be borne in mind that they may need to be adapted to suit particular



10

### Components list for figures 8 and 11

#### Resistors:

R1, R6 = 10 k  
 R2, R15 = 470 k  
 R3, R7, R9, R10, R16 = 22 k  
 R4, R5, R8 = 100 k  
 R11 = 180 k  
 R12, R14 = 47 k  
 R13 = 1M5  
 R17 = 1 k  
 R18 = 4k7

#### Capacitors:

C1, C6 = 220 $\mu$ /16 V  
 C2 = 47 $\mu$ /16 V  
 C3 = 100 $\mu$ /16 V  
 C4 = 10 n  
 C5 = 100 n  
 C7, C8 = 10 $\mu$ /16 V

#### Semiconductors:

ICa, ICb = CD4011A  
 T1 = TUP  
 T2 = BC140 or equ.  
 D1 ... D8 = DUS

Figures 10 and 11.  
 Board and component layout for figure 8.

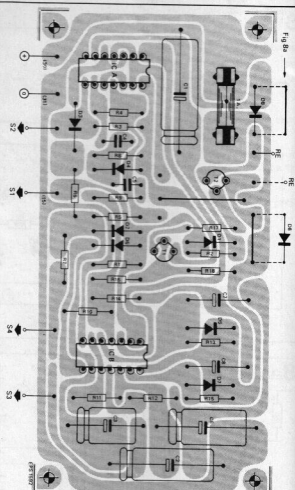
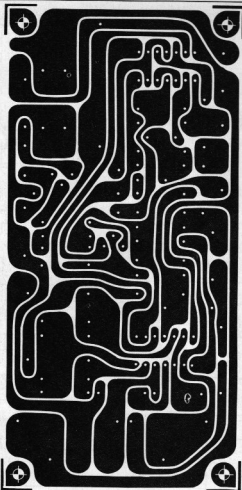

types of car. For instance, some horn relays have one end of the coil and the contact commoned, so they would not work in the circuit of figure 1. A separate heavy-duty relay (6A contacts) would have to be used. This problem does not arise with the more sophisticated designs, and a normal horn relay may be used. A printed circuit board layout is given in

figures 10 and 11 for the alarm circuit of figure 8 and this has alternative sets of connections for the relay, as shown in figure 8a, to suit different car wiring. S<sub>5</sub> in both circuits is the original push-button for the horn.

### Final Remarks

The designs discussed in this article give

varying degrees of protection at varying cost. It should be remembered that any protection is better than none — the majority of thieves are amateurs and will be deterred by even the simpler circuits described.

## string sound

This circuit can be used to give quite a natural imitation of a vibrating string. An astable multivibrator consisting of

transistors T<sub>1</sub> and T<sub>2</sub> produces the fundamental tone. As long as switch S is not operated, the two transistors T<sub>3</sub> and T<sub>4</sub> are conducting, and thus the multivibrator output is short-circuited. When S is operated, the short-circuit is removed, and T<sub>2</sub> is turned on whilst T<sub>3</sub> is cut off. At the same time T<sub>6</sub> conducts momentarily, C<sub>5</sub> discharges and T<sub>4</sub> is thus also cut off. The generator signal now occurring at the output slowly disappears as capacitor C<sub>5</sub> charges again. If

S is closed before the tone has disappeared, it is abruptly cut off because T<sub>3</sub> is turned on again.

With this circuit a tone can be produced whose frequency depends on the setting of P<sub>1</sub> and on the values of C<sub>1</sub> and C<sub>2</sub>. The values for these capacitors can be determined by experiment; they will generally be chosen in the range 1 ... 10 n. If several of these stages are interconnected via resistors, a simple synthesizer can be built.

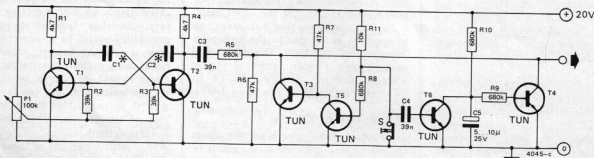

\* see text

4045-0

# h-l logic tester

This is a TTL logic probe which, instead of the usual LED to indicate the logic states, uses a seven-segment Minitron or LED display to indicate 'H' for a high or '1' state and 'L' for a low or '0' state. The circuit also detects when the probe input is open-circuit and the readout is suppressed, thus indicating that contact with the desired test point has not been made. This avoids the false readings that may occur with some types of probe when the input is not connected.

The circuit makes use of a 7447 decoder driver. The input circuitry to this IC is designed so that when the input to the probe is high a '1' is applied to the 'C' or 4 input of the IC. When the input to the probe is low a '1' is applied to the 'A', 'B' and 'D' or 1, 2 and 8 inputs of the IC. This results in the display of the number 4 and the symbol  $\square$  respectively in accordance with the truth table for the 7447. However, the connections from the outputs of the IC to the segments of the display are rearranged so that the display is actually H and L. When the input to the probe is open-circuit all four inputs to the 7447 are high (A = B =

7447 output	pin No.	connected to display segment
a	13	not connected
b	12	not connected
c	11	c, g
d	10	e
e	9	d
f	15	not connected
g	14	b
		f

Truth Table for exclusive-OR gate

A	B	C
0	0	0
0	1	1
1	0	1
1	1	0

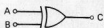

C = D = 1, i.e. '15') and the display is completely suppressed.

The input circuitry operates as follows: N<sub>1</sub> and N<sub>2</sub> are exclusive-OR gates. When a '0' is applied to the probe input both inputs of N<sub>1</sub> are '0' so the output is also '0'. One input of N<sub>2</sub> is held at '0' via R<sub>1</sub> and the other is held at '1', by R<sub>2</sub>, so the output is '1'. This output is connected to the A, B and D inputs of the 7447. When the probe input is '1' one input of N<sub>1</sub> is '0' and the other is '1', so the output is '1'. This output is connected to the C input of the 7447. Both inputs of N<sub>2</sub> are '1', so the output is '0'. When the probe input is open-circuit the input of N<sub>1</sub> is not connected to ground floats at just above the '1' threshold level, so the output is '1'. The forward voltage drop of D<sub>1</sub> and D<sub>2</sub> prevents this from holding the input of N<sub>2</sub> high, so the input is held low by R<sub>1</sub>. The other input is, of course, held high so the output is '1'.

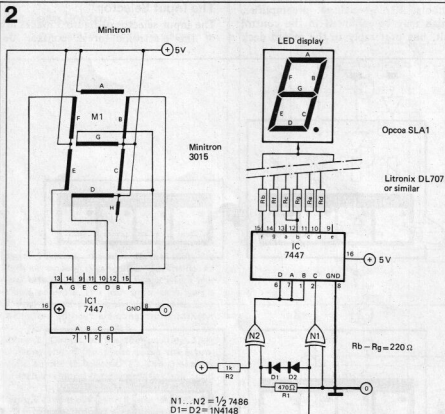
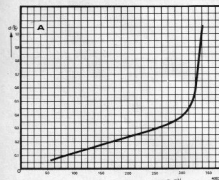

Figure 1. Connections from outputs of 7447 to display segments.

Figure 2. Complete Circuit of the H-L tester, showing the alternative connections for Minitron and LED display.

## measurement results

Input impedance: 60 ... 160 k $\Omega$ , depending on  
 Input sensitivity: 70 ... 170 mV (adjustable)  
 Output impedance: 1k $\Omega$  or up to 4k7, depending on  
 Maximum output level: 180 mV (or up to 850 mV)  
 S/N ratio: better than 60 dB  
 Input selector: suppression of unwanted inputs: better than 60 dB  
 Crosstalk: adjustable;  
 in stereo position: -40 ... -50 dB,  
 100 Hz ... 10 kHz  
 Current consumption: approx. 200 mA (10 V)  
 Distortion, as a function of the output voltage from the input selector stage: see graph A



Tone control characteristics: see graph B

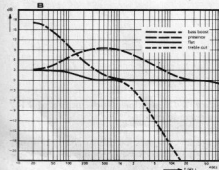

## part 2

# tap preamp

The first part of this article discussed an audio pre-amplifier and control unit operated entirely

by TAP's and dealt with the design of the TAP and the electronic switching controlled by the TAP. This month's article deals with the application of these circuits to a complete touch-controlled preamp with the facilities already described.

A block diagram of the preamp and control unit is given in figure 1. The input selector, with inputs for four signal sources, is followed by a tone control that provides bass lift, presence (middle lift), treble cut, or a flat response. (It should be noted that the touch control panel shows a symbol which could be interpreted as 'treble lift' in the fourth position.) The signal is then fed into a circuit that controls the image width from mono to 'enhanced stereo' by introducing crosstalk between the channels. The signal is fed finally to a volume control that provides four preset gains.

The disc input must be preceded by a suitable RIAA-equalised preamplifier, which may be mounted in the control unit, but preferably in the record deck

as this will give better hum figures and (provided the disc preamp has a low output impedance) the frequency response will be unaffected by cable capacitance.

The TAP, which controls all the functions, is shown in figure 2. Its operation was described in detail in last month's article, but basically, touching any one of the inputs causes the corresponding Q output to become '1' and all the other outputs to become '0'. Only one Q output can be '1' at any time. The Q output of the TAP are connected to the corresponding Q inputs of the input selector, tone, width and volume controls.

### The Input Selector

The input selector of figure 3 makes use of the electronic 'break contact' de-

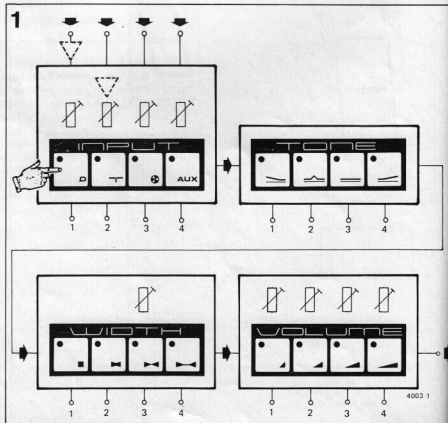

2

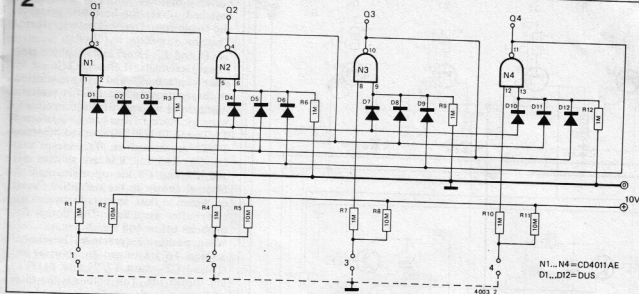

scribed in last month's article to short out the unwanted signals. When one of the inputs 1-4 is selected the corresponding transistor (T1-T4) is turned on. The corresponding pair of transistors for left- and right-hand channels (T5/T6-T11/T12) are turned off so that the desired signal can reach the base of T15 and T16. All the other pairs of transistors are turned on and short the unwanted signals to ground.

The presets on each input allow adjustment of input sensitivity and channel balance to correct channel imbalance in the signal sources. The channel balance of the preamplifier itself may be adjusted by presets in the volume control stage.

### The Tone Control

The tone control circuit is shown in

3

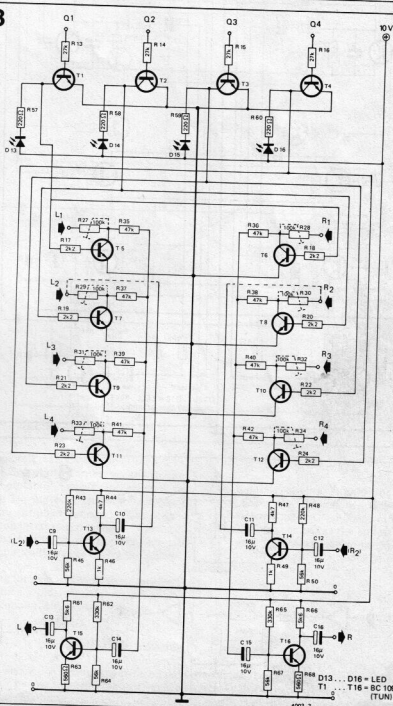

Figure 1. Block diagram of the complete touch-controlled preamplifier consisting of input selector, tone, stereo image width and volume controls. The four units each have a nominal gain of one, so any unit or units may be omitted without affecting the sensitivity.

Figure 2. Circuit of the four-position TAP. Touching one of the inputs causes the appropriate output to become '1'. The Q outputs are used to control the preamplifier functions.

Figure 3. Circuit of the input selector. T13 and T14 provide additional amplification for low-output tuners and can be dispensed with if not required. Presets R27-R34 are used to adjust for the same nominal output for all signal sources. For high-level inputs the value of these presets can be increased to 1 M $\Omega$ .

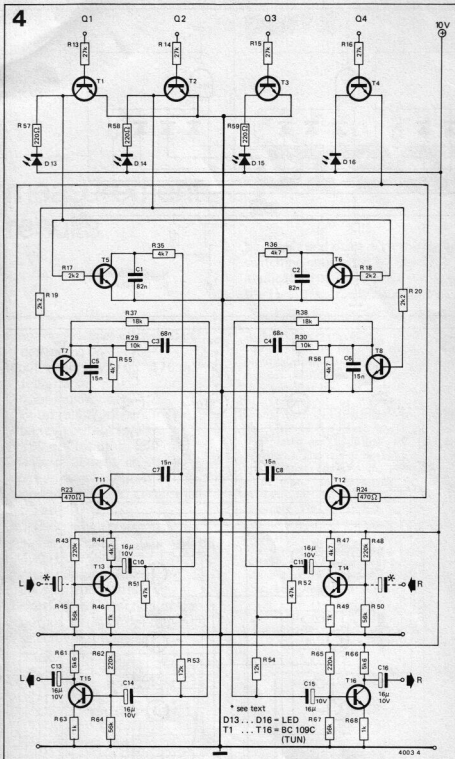

figure 4. It consists of input and output buffer amplifiers T13-T16 with three switched filters for bass lift, presence and treble cut interposed between them. The circuit operates as follows:

T5/T6 and T7/T8 act as normally closed (break) contacts. T9 and T10 act as make contacts. T11 and T12 act as make contacts. T9 and T10 are omitted as they correspond to the flat position (position 3) where no filter is in circuit. When position 1 (bass boost) is selected T5/T6 and T11/T12 are turned off while T7/T8 are turned on. This means that C5, C6, R55 and R56 are shorted out and C7 and C8 are open-circuited. A filter as shown in the simplified circuit of figure 5 thus appears between the two buffer amplifiers. This boosts frequencies below 400 Hz.

When position 2 (presence) is selected T5 and T6 are turned on, shorting out C1 and C2, whilst T7/T8 and T11/T12 are turned off. This connects the filter of figure 6 in circuit. This is a band-pass filter, which boosts the signal over the range 200 Hz to 4 kHz, with a maximum mid-band boost of about 10 dB. Position 3 is the flat position with T5/T6 and T7/T8 turned on and T11/T12 turned off. The circuit of figure 7 therefore results, which is of course simply an attenuator with no frequency-dependent characteristics. In position 4 (treble cut) all the transistors T5-T12 are turned on and the circuit of figure 8 results. At frequencies away from those at which the filters have their effect the nominal gain is one in all positions. This ensures that switching from one filter position to another does not result in large changes in volume.

### Stereo Image Width Control

This control alters the separation between channels by introducing crosstalk from one channel into the other. The image width may be varied from a mono signal, where each output channel contains an equal proportion of left and right inputs, to 'enhanced stereo', where crosstalk is introduced in antiphase to increase the image width beyond that of normal stereo. The circuit (shown in figure 9) operates in the following manner:

T13 and T14 function as a difference amplifier. That is to say that the signal

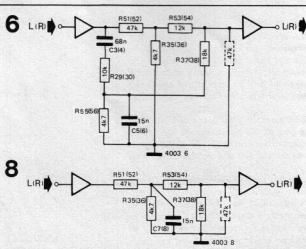
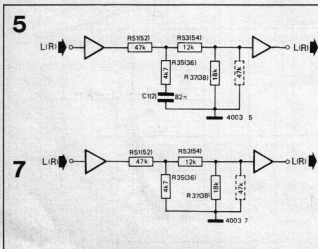

appearing across their collectors is proportional to the difference between the left and right input signals to their bases. If, for example, the right input is grounded and the left input is fed with a signal then the signal on the collector of T14 is proportional to the left input and  $180^\circ$  out of phase with the signal on the collector of T13. The same argument holds true if the left input is grounded. When both inputs are driven the outputs at the collector of T13 and T14 consist of left channel with a proportion of antiphase right channel and right channel with a proportion of antiphase left channel. That is to say, the crosstalk appearing in the signal at the collector of T13 is  $180^\circ$  out of phase with the right channel signal appearing at the collector of T14 and vice versa.

In-phase crosstalk may be introduced into these signals by mixing with the opposite channel at the base of T15 and T16 respectively. When no in-phase crosstalk is introduced the signals appearing at the collectors of T15 and T16 consist of the original signal plus the antiphase crosstalk and the image width is increased. When the proportion of in-phase crosstalk is the same as the proportion of antiphase crosstalk the two cancel and only the original signal remains. This is normal stereo. When the in-phase crosstalk exceeds the antiphase crosstalk the net result is a proportion of in-phase crosstalk and the stereo image width is reduced; finally, when the crosstalk equals the signal a mono output results.

When position 1 (mono) is selected transistors T7-T12 are cut off. This means that crosstalk from the collector of T14 is fed into the base of T15 together with the left channel signal from the collector of T13 and vice versa. When position 2 (reduced width stereo) is selected T9 and T10 are turned on, grounding R37 and R38 respectively. R51, R37 and R52, R38 thus form attenuators that reduce the amount of in-phase crosstalk. The same applies to position 3 (normal stereo) when T9 and T10 are turned on, but R39 and R40 are chosen so that the in-phase crosstalk equals the antiphase crosstalk and the two cancel. R39 and R40 may be replaced by presets so that the circuit can be trimmed to cancel

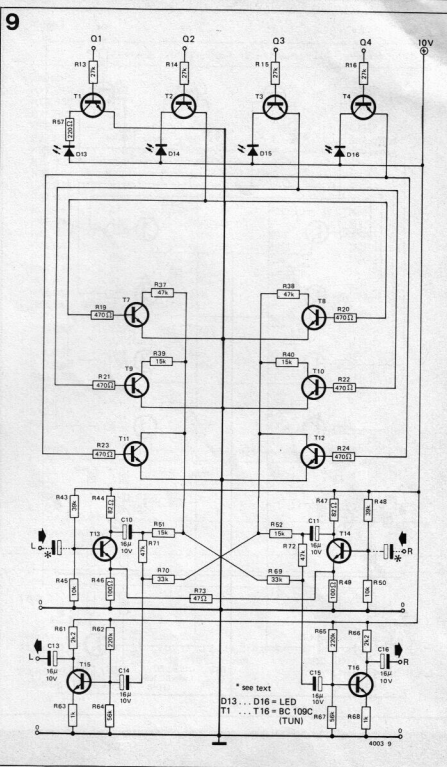

Figure 4. The tone control unit. The four positions give bass boost, middle lift (presence), flat response and treble cut respectively.

Figures 5-8. Simplified equivalent circuits of the tone control in the four positions mentioned.

Figure 9. Circuit of the stereo image width control. This has four positions from mono to enhanced stereo with different amounts of crosstalk introduced between the channels to vary the separation.

the crosstalk exactly. In position 4 T11 and T12 are both turned on and the in-phase crosstalk signals are shorted to ground leaving only the original signals plus the antiphase crosstalk. This results in an enhanced stereo image width.

Looking at the operation of the circuit mathematically we can derive the following:

ignoring the gain of the difference amplifier, which affects all components of the signal equally, we can say that

$$L_C = -L + k_1 R$$

where  $L_C$  is the signal at the collector of T13, L and R are the left and right inputs and  $k_1$  is a constant determined by the parameters of the difference amplifier. Similarly

$$R_C = -R + k_1 L$$

The minus signs are due to the  $180^\circ$  phase change in T13 and T14 respectively. After mixing with in-phase crosstalk the signals appearing at the collectors of T15 and T16 (again ignoring the gain, which affects all components of the signal equally) are

$$L_O = -L_C - k_2 R_C,$$

and

$$R_O = -R_C - k_2 L_C$$

where  $k_2$  is a constant whose value is selected by switching in the different attenuators that introduce varying proportions of in-phase crosstalk.

10

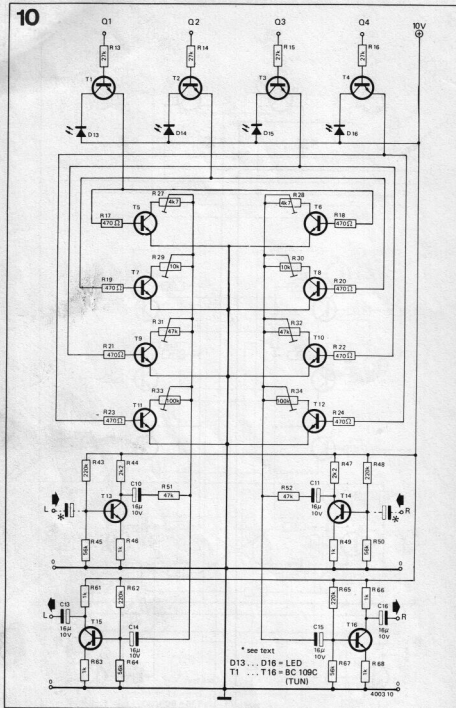

Figure 10. The four-level volume control, which may be preset to the desired listening levels and may be used to adjust channel balance.

Figure 11. Pattern of the universal p.c. board used for each of the four units of the pre-amplifier.

Therefore

$$L_0 = L - k_1 R + k_2 R - k_1 k_2 L \\ = L(1 - k_1 k_2) + (k_2 - k_1) R$$

$k_1$  was chosen subjectively and it was found that a value of 6 dB ( $X \frac{1}{2}$ ) of anti-phase crosstalk gave the best results. This immediately gives some of the values for  $k_2$ .

For a mono signal the proportions of L and R in the output must be equal i.e.

$$1 - k_1 k_2 = k_2 - k_1$$

which means that  $k_2 = 1$ .

For a normal stereo signal the crosstalk must be zero i.e.

$$k_2 - k_1 = 0$$

which means that  $k_2 = \frac{1}{2}$ .

For enhanced stereo there must be only antiphase crosstalk i.e.

$$k_2 = 0.$$

The value of  $k_2$  for a reduced width stereo signal (position 2) is purely a mat-

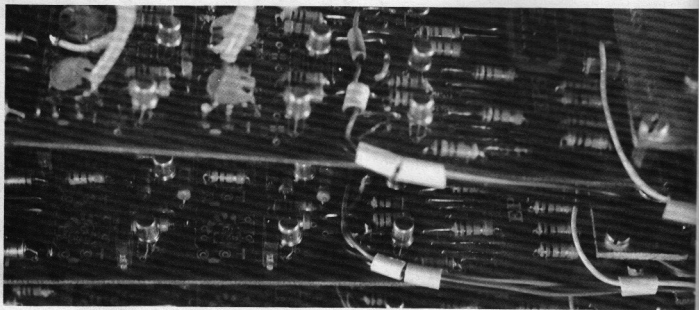

ter of personal taste depending on the image width required and may be adjusted by changing R39 and R40 in figure 9.

### Volume Control

This was discussed briefly in last month's article and the complete circuit is given in figure 10. Selecting one of the positions turns on the corresponding pair of transistors T5/T6-T11/T12, grounding the potentiometers connected to each collector. These form attenuators with R51 and R52 which control the levels of the signals fed into the bases of T15 and T16 respectively. The degree of attenuation produced in each position may be altered by the potentiometers to suit personal taste and to adjust the channel balance.

### Construction and Adjustment

The four units described are each constructed on a universal printed circuit board, the pattern for which is given in figure 11. The component layouts for the different units are detailed in figures 12-15 and the parts lists are given in the tables 1 and 2. The components common to every board are given in table 1 and those particular to one unit are given in table 2. The capacitors marked \* in figures 4, 9, and 10 may be omitted if all 4 boards are used together but should be included if any board is used on its own.

Setting up of the units is a simple matter. The input potentiometers of the input selector stage are adjusted so that the output of this stage is about 100 mV when fed with the nominal signal level of each source. Thus, if the system is to be used with a tuner of nominally 100 mV output the tuner input should be adjusted with 100 mV input signal from an oscillator. If no test equipment is available the circuit may be adjusted using the actual signal sources (disc, radio, tape etc.) and listening on headphones each input potentiometer may be adjusted to give approximately the same volume level. Balance between channels should also be adjusted to compensate for im-

Table 1

	Figures 3, 12	Figures 4, 13	Figures 9, 14	Figures 10, 15
<b>Resistors:</b>				
R17, R18	2k2	2k2	X	470Ω
R19, R20	2k2	2k2	470Ω	470Ω
R21, R22	2k2	X	470Ω	470Ω
R23, R24	2k2	470Ω	470Ω	470Ω
R27, R28	100 k preset	X	X	4k7 preset
R29, R30	100 k preset	10k	X	10k preset
R31, R32	100 k preset	X	X	47k preset
R33, R34	100 k preset	X	X	100k preset
R35, R36	47k	4k7	X	X
R37, R38	47k	18k	47k	X
R39, R40	47k	X	15k	X
R41, R42	47k	X (C7,8)	—	X
R43, R48	220k	220k	39k	220k
R44, R47	4k7	4k7	82Ω	2k2
R45, R50	56k	56k	10k	56k
R46, R49	1k	1k	100Ω	1k
R51, R52	X	47k	15k	47k
R53, R54	—	12k	X	—
R55, R56	X	4k7	X	X
R57	220Ω	220Ω	220Ω	—
R58, R59	220Ω	220Ω	—	—
R60	220Ω	—	—	—
R61, R66	5k6	5k6	2k2	1k
R62, R65	330k	220k	220k	220k
R63, R68	560Ω	1k	1k	1k
R64, R67	56k	56k	56k	56k
R69, R70	X	X	33k	X
R71, R72	X	X	47k	X
R73	X	X	47Ω	X
<b>Capacitors:</b>				
C1, C2	X	82n	X	X
C3, C4	X	68n	X	X
C5, C6	X	15n	X	X
C7, C8	(R41, R42)	15n	—	(R41, R42)
C9, C12	16μ/10 V	—	—	—

(X = omitted; — = wire link)

Table 2

<b>Resistors:</b>	<b>Capacitors:</b>	<b>Semiconductors:</b>
R1, R4, R7, R10 = 1 M	C10, C11, C13, C14, C15, C16 =	D1 ... D12 = DUS
R2, R5, R8, R11 = 10 M	16μ/10 ... 16 volt	D13 ... D16 = LED
R3, R6, R9, R12 = 1 M		T1 ... T16 = BC109C or equ.
R13, R14, R15, R16 = 27k		IC1 = CD4011AE

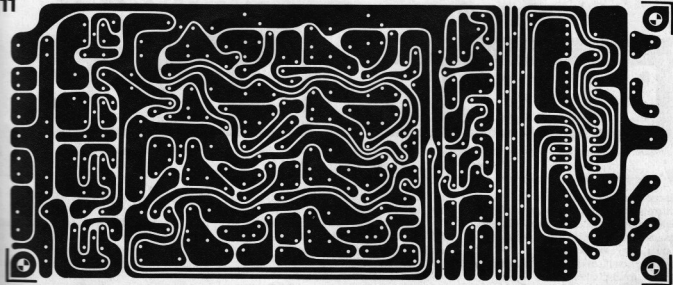



12

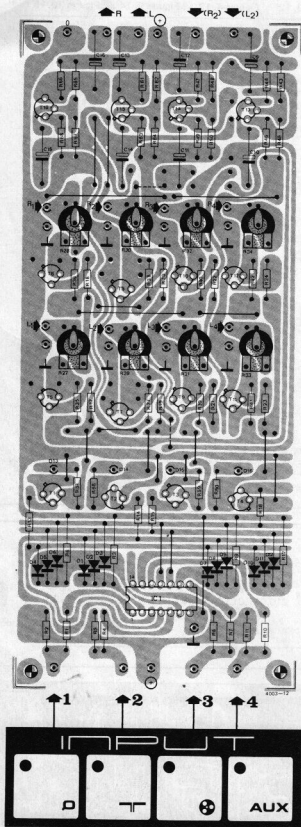

Figure 12. Component layout for the input selector (figure 3).

balance in the signal sources. The volume control settings are next adjusted to give the desired listening levels. Channel balance may also be adjusted to compensate for any imbalance in the pre-amplifier itself or in the power amplifier and loudspeakers. The unit is now ready for use.

The output level is 200 mV; if this is insufficient for full drive of the power amplifier, R61 and R66 (figures 10 and 15) can be increased to 4k7. The output level then becomes 1000 mV.

13

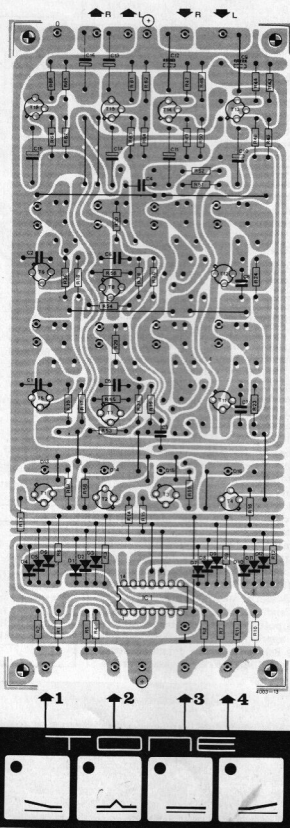

Figure 13. Component layout for the tone control stage (figure 4).

### Conclusion

All the units in the touch-controlled preamplifier have a nominal gain of unity and so may be used in any combination without affecting the performance, or they may be used in conjunction with other equipment. It is

14

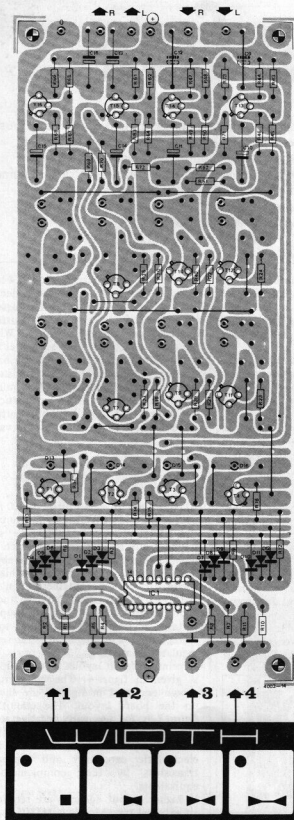

Figure 14. Component layout for the stereo width control (figure 9).

15

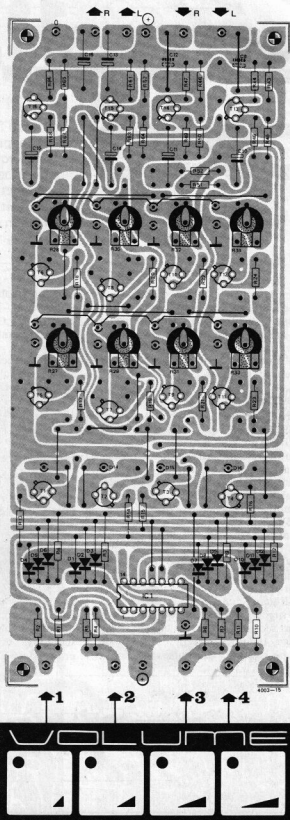

Figure 15. Component layout for the volume control (figure 10).

hoped in a later article to publish details of a touch station selector for radio and other additions to the system.

#### Design Modification

A small modification has been made to the portions of the circuit using the

'break contact'. Referring to figure 6 of last month's article, when T1 is turned off there is still a residual current of about 6 mA flowing through the LED via R3, R4 and the base-emitter junctions of T3 and T4. With certain types of LED, notably those with a clear plastic encapsulation, this may give rise to a

noticeable glow. This can be eliminated by connecting a 220  $\Omega$  resistor across the LED. Current will flow through this resistor but the voltage drop across it will be less than the turn-on voltage of the LED. This modification applies to the following: figure 3, D13-D16; figure 4, D13 and D14.

# supplies for cars

In order to function effectively, electronic equipment used in cars must have an appropriate power supply, which in addition to providing a regulated voltage from the battery supply, must also suppress interference appearing on the battery voltage from the car electrical systems. To be effective, such power supplies must of course be used in conjunction with the measures described elsewhere in this issue for the suppression of radiated interference at source.

Two power supplies will be described; a simple zener stabilizer with built-in suppression, for low-power circuits such as instruments (electronic tachometer etc.) up to about 170 mA and a high-power stabilized supply, for powering such things as portable cassette recorders, up to about 2 A.

## Low-power circuit

Figures 1 and 2 show the low-power circuit configuration for negative- and positive-earth cars respectively. L1 and D1 provide high-frequency decoupling. L1 may be wound on a wire-ended cylindrical ferrite core, with a diameter of about 10 mm, using 45 turns of 0.5 mm enamelled copper wire (25 SWG). Zener diode Z1 stabilizes the output voltage at 5.6 V, which is suitable for TTL circuitry, but 5.1 V or 4.7 V types would also do, as they are within the supply voltage limits for TTL. Other voltages may, of course, be used for different equipment.

If a supply voltage is required that is almost equal to the available battery voltage, then R1 and the zener diode may be omitted. Of course, the circuit

will then not provide stabilization of the supply voltage, but only interference suppression. This would be quite adequate for COSMOS IC's, which are fairly tolerant of supply voltage variations.

The difference between battery voltage and output voltage is dropped across R1. In the example given, for a 6 V battery R1 would be 8.2 ohm ¼ W, and for a 12 V battery 47 ohm 2 W. C2 should be a low-inductance type such as ceramic and D1 can be any diode that will carry 200 mA.

## High-Power Circuit

This circuit (figure 3) is designed to provide a stable, interference-free supply for cassette recorders, audio amplifiers and other equipment. Car radios generally have their own inbuilt suppression circuits.

The circuit is a simple feedback stabilizer. T5 and T6 form a differential amplifier with a constant-current emitter load (T7). This compares a portion of the output voltage at the slider of P1 with a reference voltage provided by D6. T3 provides a constant

current through this zener diode. T4 is a constant-current load for the collector of T6, which drives the Darlington-connected transistors T8 and T9. Current limiting is provided by T1 and T2. When the current through R4 is such that the voltage drop across it exceeds the base-emitter voltage of T1, this transistor turns on, which turns on T2, pulling down the collector of T6 and reducing the drive to T8. The maximum output current required determines the value of R4:

$$R_4 = \frac{0.5}{I_{\max}} (\Omega)$$

L1 is wound from 45 turns of 1.0 mm copper wire (19 SWG) on a ferrite core and thus provides interference suppression due to its high inductance. P1 will adjust the output between about 5.6 V and 12 V, although the higher figure can only be obtained when the (12 V) car battery is fully charged and in good condition, so that the supply voltage is around 14 V, since some voltage must be dropped across the series regulator transistor and R4.

A printed circuit layout for this supply is given in figure 4. The connections shown encircled in figure 3 are shown on the board layout. The circuit of figure 3 is for use with negative earth cars, but may be modified for positive earth simply by reversing all diodes and electrolytic capacitors and replacing transistors by their complementary equivalents.

If higher output currents are required, an external transistor (e.g. MJ3055) can be added. The connections to this transistor (T10) are shown dotted in figure 4; it should be mounted on an adequate heatsink, with mica washers for isolation. If this transistor is not required, the connections 5 and 6 on the pcb must be bridged.

To avoid deterioration of the board in the car due to humidity and dirt it is best to encapsulate the circuit (once it has been tested) in epoxy resin or silicone rubber.

1

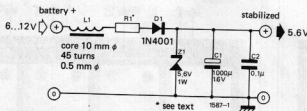

2

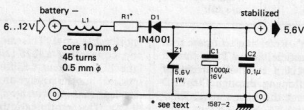

3

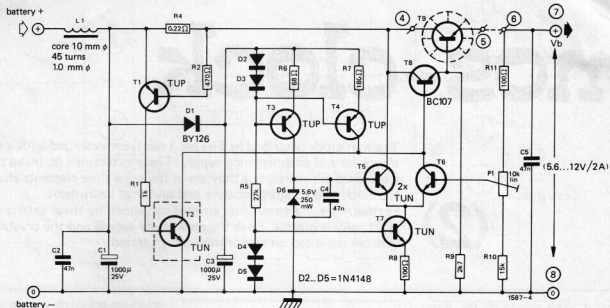

#### Part list for figures 3 and 4:

##### Resistors:

R1 = 1 k  
 R2 = 470  $\Omega$   
 R4 = 0.22  $\Omega$ \*  
 R5 = 27 k  
 R6 = 68  $\Omega$   
 R7 = 180  $\Omega$   
 R8, R11 = 100  $\Omega$   
 R9 = 2k7  
 R10 = 15 k  
 P1 = 10 k, preset

##### Capacitors:

C1, C3 = 1000  $\mu$ /25 V  
 C2, C4, C5 = 47 n

##### Semiconductors:

T1, T3, T4 = TUP  
 T2, T5, T6, T7 = TUN  
 T8 = BC107 or equ.  
 T9 = BD 131 or equ.\*  
 (T10 = MJ3055 or equ.\*  
 D1 = BY 126  
 D2 ... D5 = 1N4148  
 D6 = 5.6 V/250 mW zener

##### Coil:

L1 = 45 turns of 1.0 mm enamelled copper wire on 10 mm  $\phi$  ferrite former.

\* see text

Figures 1 and 2. Simple zener stabilized supply with high-frequency suppression. Figure 1 is for negative earth and 2 is for positive earth.

Figure 3. A high-power regulated supply for car electronics. The output voltage may be adjusted from 5.6 V to 12 V and the circuit will supply 2 A continuously.

Figure 4. P.c. board and component layout for the circuit of figure 3.

4

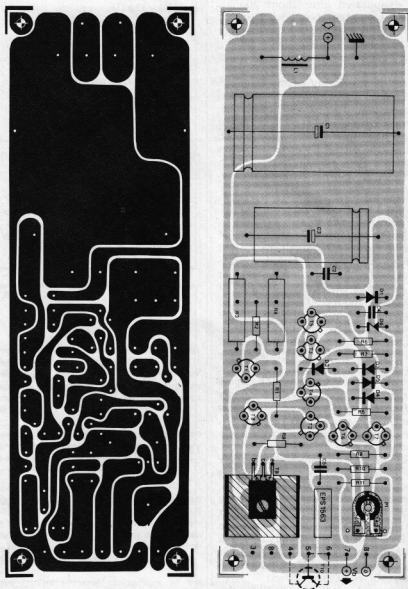

# mos-clock

## (2)

In recent years especially, the mains voltage has been liable to cut out momentarily (or even for quite some time!). Depending on the capacitance of the electrolytic in the power supply, the d.c. voltage driving the clock will have disappeared after about 200 ms. The clock will then forget what time it is, so that it must be reset. This is in itself not such an enormous problem, but a number of brief failures in one day could be annoying!

The emergency supply circuit described here uses a 9-volt battery. This provides an emergency drive for about 20 hours; a period within which even the most serious mains breakdown will have been repaired. The emergency drive also offers the possibility of moving the clock from one room to another without it stopping.

### Design

As the clock-IC MM5314 consists of one monolithic MOS circuit, its current consumption can be neglected in comparison with that of the displays. At 15 V the total current consumption of the clock is about 250 mA, 240 mA of which is drawn by the displays. This is one of the reasons why the clock-IC is provided with a so-called strobe input (pin 1 of the IC) which is '1' when the clock is running normally. If, however, the strobe input is made '0', the display is suppressed, and only the divider circuits and the memory still draw current.

These circuits still function satisfactorily at a supply voltage of 7 V.

So for an effective emergency supply from a small battery it is essential that as soon as the normal supply cuts out, the strobe input becomes '0' so that current consumption drops to about 8 mA. Of course, it must be possible to switch on the display circuits now and again on the emergency supply. A circuit which provides for this is given in figure 1.

If the mains voltage is available, the circuit is driven via point BS from the secondary of the transformer. This

The mos-clock described in Elektor 1 has been extended with a crystal time base and an emergency supply. These extensions do make the clock a bit more expensive, but they are at the same time elements changing the clock into a highly-accurate and universal instrument. Furthermore, the total extra current consumed by these extensions is practically negligible. Both the emergency supply and the crystal time-base are mounted on one printed circuit board.

### Parts list for figures 1, 2, 5, and 7.

#### resistors:

R1, R3 = 100 k  
R2, R7 = 27 k  
R4 = 10 k  
R5 = 120  $\Omega$   
R6 = 15 k  
R8 = 47 k

#### capacitors:

C1 = 0.1  $\mu$   
C2 = 5 ... 30 p trimmer  
C3 = 15 p  
C4 = 220  $\mu$ , 10 V

#### semiconductors:

T1, T2, T3 = BC 107 B or equ.  
D1 = BAY 61, BA 127  
D2, D3, D4, D5, D6 = DUS  
IC1 = ICM 7038 A (intertil)

#### miscellaneous

S1 = push button with break contact  
X-tal = 3.2768 MHz crystal; parallel resonance with external 12 p  
8-pin DIL IC-base for IC1

point is indicated on the clock P.C. board. The transformer secondary voltage on BS is rectified via D1, so that capacitor C1 is charged. Then transistor T1 is driven into saturation via resistor R1. The collector voltage of this transistor is then so low that transistor T2 is not driven. Via resistor R4 and push-button S1 the collector of T2 is connected to the strobe input of the clock-IC. This point (SB) is also indicated on the clock p.c.b. When transistor T2 is off, the strobe input of the clock-IC is connected to a relatively high-impedance load so that it 'sees' a '1', causing the displays to light up.

If, however, the mains voltage cuts out, point BS in figure 1 no longer carries a voltage, and C1 discharges so rapidly that transistor T1 is cut off within 5 ms. Now the base of T2 is driven via resistors R2 and R3, so that its collector-to-emitter resistance drops to about 200 ohms. As a result point SB becomes '0' via resistor R4 and the supply for the display circuits is cut off inside the clock-IC.

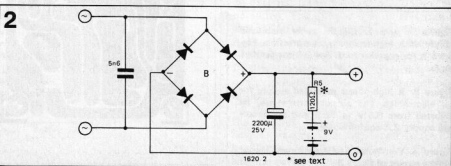
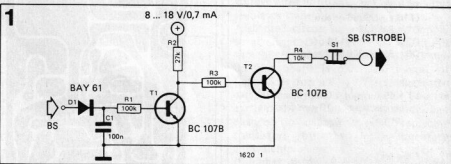

3

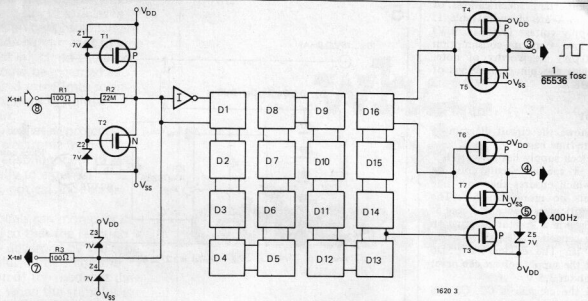

When button S1 in figure 1 is depressed, the strobe input of the clock-IC becomes '1' again and the displays light up. Instead of a push button, a single-pole switch can be used for S1.

### Practical version

For the emergency supply, only a battery with a series resistor need be connected across the supply electrolytic capacitor of the clock proper. Figure 2 shows the relevant detail of the clock supply: the extra battery and the series resistor R5 are in parallel with the supply elco. A so-called minipower pack will do as the battery. The design of the p.c.b. is based on this type of battery.

Two alternative arrangements are also possible. The first is to replace R5 by a diode, with the anode connected to the battery and the cathode connected to the supply rail. This has the advantage that the full battery voltage is available to drive the displays for short periods on emergency drive. However, it also means that no 'refresher' current runs through the battery when the mains is on.

Perhaps the best arrangement of all is to replace R5 by a diode, as above, and add an extra resistor of 100 k in parallel to the diode. This will trickle-charge the battery.

In all cases it is advisable to check the battery condition occasionally (by disconnecting the mains). This is particularly important when 'dry' batteries are used - they sometimes become very wet after a period of time, as many owners of portable radios and torches have discovered to their cost!

### Crystal timebase

Although the standby supply will maintain the information in the memory of the clock in the event of a mains failure, the counting circuits will not operate in the absence of a 50 Hz signal. This is where the crystal timebase comes in. It ensures good timekeeping accuracy (approx. 10 seconds per month) and makes the drive to the clock independent of the mains.

Table 1.

Some specifications of the Intersil IC type ICM 7038 A.

supply voltage	: 1.6 V ... 4 V (max. 5 V)
current consumption	: 60 $\mu$ A ( $V_b = 2.2$ V); 130 $\mu$ A ( $V_b = 3.6$ V)
output resistance	: 230 $\Omega$ both for p- and n-output condition ( $I_o = 3$ mA)
minimum oscillator frequency	: 0.2 MHz ( $V_b = 1.6$ V)
maximum oscillator frequency	: 10 MHz
power dissipation	: 300 mW maximum
input voltage oscillator	: $\leq V_b$
case temperature	: $-30^\circ$ C ... $+125^\circ$ C maximum
ambient temperature	: $-20^\circ$ C ... $+70^\circ$ C maximum
output voltage	: $\approx V_b$ at all outputs
output current at $V_o = 0$	: 80 mA maximum
$V_o \approx V_b$	: 18 mA maximum
400 Hz output current ( $V_a \approx V_b$ )	: 30 mA maximum
400 Hz output resistance	: 200 $\Omega$ ( $I_a = 3$ mA)

4

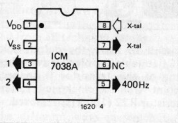

Figure 1. With the mos-clock, the displays draw most of the current. If the clock is provided with a circuit that drives the 'strobe' when the mains cuts out, the emergency battery will keep the clock itself running for about one day.

Figure 2. The mos-clock can easily be provided with an emergency supply. A 9-volt battery and a series resistance of 120  $\Omega$  will do.

Figure 3. The intersil IC type ICM 7038 A comprises a.o. a 16-stage divider and a crystal oscillator. For the oscillator only the crystal and two capacitors need be connected externally. The IC is built up from complementary MOS-circuits, so that the power dissipation is extremely low.

Figure 4. The external connections of the ICM 7038 A. Owing to the COS/MOS properties, it is always advisable to use a base or socket for this IC.

For this crystal time base use is made of a complementary MOS IC which, besides an oscillator, also comprises the dividers necessary for obtaining the 50 Hz square-wave voltage with which the clock is driven.

Figure 3 gives a simplified block diagram of this IC, the INTERSIL ICM 7038 A. Transistors T1 and T2 in figure 3 are a part of the crystal oscillator. Two external capacitors and the crystal are connected between points 7 and 8. The oscillator is followed by an inverter (1) which is turn is followed by 16 divider stages. The 16th divider is followed by two inverse output stages at which a relatively low-impedance square-wave voltage is available for further processing. The divider stages D1...D16 are all binary so that after the 16th divider we have a frequency of:

$$f = f_0/2^{16} = f_0/65536$$

Here  $f_0$  is the oscillator frequency and  $f$  the output frequency behind the 16th divider.

It is also apparent from figure 3 that all important points are protected by means of zener diodes. This does not imply, however, that the IC can be handled as if it were TTL: due care is always recommended. Touching the connecting pins of the IC must be avoided as much as possible, whilst the IC can best be mounted on the p.c.b. by means of a socket.

The most important specifications of the ICM 7038 A are given in table 1. The low supply voltage (1.6 . . . 4 V) and the low current consumption (average 90  $\mu$ A) are worthy of note. Figure 4 gives the pin connections of the ICM 7038 A.

### The circuit

Figure 5 shows the circuit diagram of the complete time base.

Since the clock supply lies between 8 V and 18 V, a special circuit must be provided which ensures that the time base IC gets no more than 5 V. The simplest solution is shown in figure 5: the IC is fed via a resistor R6, and an electrolytic capacitor (C4) is connected across the IC. The diodes D2 . . . D6 ensure that the supply voltage can never rise above about 3.5 V.

In figure 5 the capacitors C2, C3 and the crystal are the external components

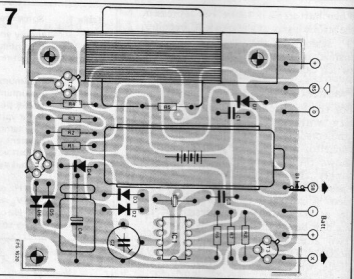
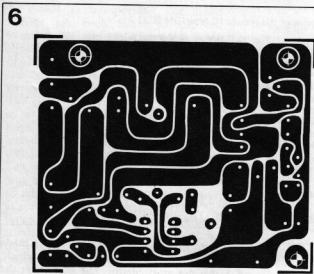
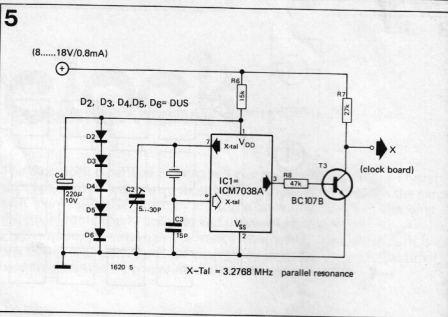

for the oscillator. The crystal must be of a type that has been ground for parallel resonance with an external parallel capacitance of 12 pF nominal. For 50 Hz output reference the crystal frequency must be 3.2768 MHz. The oscillator can be adjusted with capacitor C2.

Transistor T3 has been included in the

circuit to make the output voltage of IC1 suitable for clock drive. The collector of this transistor is connected to point X on the clock p.c.b., after which resistor R22 (100 k) is removed.

### The printed circuit board

Figure 6 shows the lay-out of the printed circuit board on which the

circuits of figures 1, 2 and 5 can be mounted. The component arrangement of these circuits is given in figure 7.

Figure 8 shows a photograph of the board. It can be mounted on the mains transformer on the original clock board.

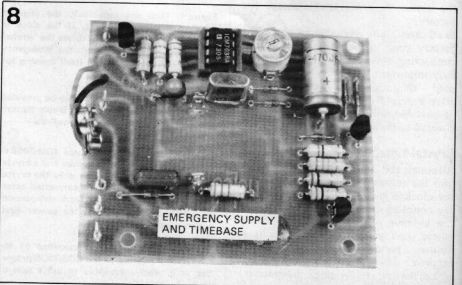

Figure 5. The complete 50-Hz reference source for the mos-clock. The diodes D2 . . . D6 are for protection and ensure that the supply voltage for the IC cannot rise above about 3.5 V. T3 is needed because the output voltage of the IC is too low to drive the clock input directly.

Figure 6. The lay-out of the printed circuit board for the circuits of figures 1, 2, and 5.

Figure 7. The component arrangement on the printed circuit board of figure 6.

Figure 8. Photograph of the complete printed circuit board with the circuits of figures 1, 2, and 5.

The 'cybernetic beetle' is the first of a series of articles in 'Elektor' on designs which are on the one hand meant to be a game, but which on the other hand should be regarded as serious and sometimes scientific imitations of animal behaviour.

These cybernetics projects have an electronic 'nerve system' enabling them to react specifically to external acoustic, optical and tactile stimuli.

Such models can moreover be designed so that the reaction is not only governed by the type of stimulus, but also by the condition of the model at the moment when the stimulus is applied. The more 'natural' the relationship between the stimulus and the relevant reaction, the more the behaviour of the model approaches that of the animal example and the more will an ingenious toy become a scientific object.

It was found to be extremely difficult to imitate the behaviour of more highly developed animals in a cybernetic model, because an electronic nerve system can only perform a limited number of functions. Experiments on a scientific basis therefore confine themselves to certain aspects of behaviour or to living models of a very simple nature.

Although the nature of the nervous system is as yet unknown, it is interesting to see that at any rate the models behave in a typically 'animal-like' way so that their reaction to a certain stimulus cannot be predicted.

These cybernetic models derive their attraction from the fact that the spectator unconsciously interprets the purposefulness or the learning capacity of artificial animals as a sign of intelligence. Here the question immediately arises whether it is possible to build a 'thinking' machine.

It would carry us a little too far to use this series of articles for entering into these undoubtedly highly interesting and topical problems. The cybernetic aspects of the electronic animal models will, however, be dealt with more extensively. (Ed.)

H. Ritz

# what is cybernetics?

The word 'cybernetics' which has in recent years taken a permanent place in our vocabulary, is of Greek origin and means approximately 'art of steering'. The Greeks used it to denote the skill of a pilot who steered a ship safely into harbour. At present the term denotes a new branch of science which still has something to do with the art of steering. In 1948 Norbert Wiener founded this branch when he wrote his: 'Cybernetics - the science of control and communication, in the animal and the machine'. The title of this book already shows that the sphere of influence of cybernetics encompasses all dynamic systems, both natural and artificial. For a cybernetic investigation of such systems it is irrelevant of what material they are made and by what force they are driven. The only thing that matters is the abstract system detached from all technical details.

It will therefore be clear that cybernetic investigations may also concern other dynamic systems, such as economics, but of course it is technology that profits most by cybernetics.

It is the different ways in which the dynamic systems behave that are of interest to cyberneticians. The behaviour of living organisms is then frequently compared with that of a technical imitation, a model.

A toy train driven by a spring motor running in circles on its rails is a dynamic system. Yet, this model track is of no interest to cyberneticians, because no behavioural patterns can be observed. A system which has to develop certain behavioural patterns must also have a few properties other than dynamic ones only, viz.:

1. It must be able to receive external information coded in signals;
2. It must be able to store this information and hence have a memory;
3. It must be able to convert stored information into reactions. These reactions must be controlled, which means that external interference must always be effectively reacted to. Reactions do

not conform to a previously fixed programme, but are always compared first with previous reactions and their results. All cybernetic control systems are based on this feedback principle.

4. Because they are capable of self-correction, cybernetic systems always display a purposeful behaviour.
5. Cybernetic systems are stable. By this we mean a dynamic stability which enables the system to return to a certain situation after a breakdown. Non-cybernetic machines cannot cope with external interference. They only function if possible causes of interference are known beforehand and if the appropriate counter-measures have been incorporated in the machine. A cybernetic machine, on the contrary, can also deal with interference not previously taken into consideration.
6. Higher-level cybernetic systems can 'learn'. They can adapt their behaviour if experience gained gives them cause for doing so.



Arbeitsgemeinschaft der  
Hauptschule Rossbach (Siegl).

# beetle

Beetles, tortoises and the like have often served as models for cybernetic machines which must also have a reasonable appearance. The beetle described in this article can 'see, hear and feel' and reacts to information in the form of sounds and movements. The animal has a memory and can get tired. The beetle is the first of a series of articles on cybernetic models.

## The behaviour of the beetle: action and reaction

In daylight (vertical light) the model moves slowly forward in a circle (counter-clockwise) with a diameter of approx. 80 cm. If during its journey the beetle arrives in a place where there is less light (for instance in a dark corner or below a chair), it rests in the shade for approx. half a minute to a full minute and then resumes its circular journey.

It is also possible that, instead of continuing the model decides to take a prolonged rest in the shade: it 'falls asleep'. This condition of prolonged rest can only be altered by external stimuli. The object casting the shadow is removed or the model is wakened by a loud sound (clapping). If the beetle 'sees' a horizontal light source on its journey, it makes a beeline for it. Any deviations from its course are automatically corrected.

If the model hits an obstacle on its path, it gives a brief cry of fright and immediately shrinks back. This reverse movement is, however, preceded by a short turn, so that when the beetle resumes its forward movement after 3-4 seconds, it is positioned obliquely with respect to its previous direction of travel. Because the beetle can now no longer see the light source, it again starts a left turn, which results in a second collision with the obstacle, somewhat more to the left than the first time. Thus, after a few repetitions, extensive obstacles are also dodged, after which the beetle heads for its goal (phototropism).

When the horizontal light source is reached, the model will collide with it and the above-mentioned swerving movements will follow. As a result, the model will find its way behind the light source. If this horizontal light source does not emit light backwards and if there is also a shady area at the rear of the lamp, the model goes behind the lamp to enjoy a short or prolonged period of rest.

The model can also learn. If at the moment of the collision a warning sound (clapping) is made, the model concludes that the collision (pain) and clapping

belong together. For this reason, if a warning sound is made when the model is moving forwards, it will now first give a cry of fright and then perform the same swerving movement which would otherwise be performed in the case of an actual collision.

The memory fades, however, during a rest in the shade. After such a pause the model hesitates briefly when the warning sound is made; it listens for a moment and immediately after the hand-clapping the forward movement is resumed.

In general this simple cybernetic model behaves in a typically animal-like way. It can move, see, hear, feel, it reacts efficiently to certain external interferences, acts purposefully and has also certain reflexes in addition to the senses of touch and hearing.

Things become even more interesting if two models are available, each with a light source on its back. If moreover the cry of fright of one beetle is tuned to the warning sound of the other, an exchange of experience may take place. The innumerable possibilities of searching, pursuing and swerving guarantee an interesting course of experiments.

As is indicated by dashed lines in the block diagram (figure 1) a 'hunger' sensation can be added. This part immediately interrupts a journey or a period of rest when the battery voltage drops below a

certain minimum. The model then heads for a second lamp placed near a charging unit. If on the way to the charging unit the beetle starts to use less current for some reason, it records that sufficient energy is still left to resume the normal search for the first lamp. If this effect is undesirable, a flip-flop can be used instead of gates  $N_{15}/N_{16}$ . After charging the reset function must be performed by hand.

For demonstrations it is advisable to use a potentiometer as supply control; the beetle's 'hunger' may then be artificially generated by increasing the potentiometer's resistance.

## The various functions

The drive motor (DM) runs only if the vertical-light receiver (VLR) receives light from above and the warning receiver (WSR) does not receive sound, or, in darkness, if a short rest (SR 40 sec.) initiated by the VLR has elapsed and the flip-flop (LR) for a prolonged rest is not in 'prolonged' position. A warning sound makes the motor stop briefly and trips the flip-flop for prolonged rest. Furthermore the drive motor starts running if a warning unit (BW) detects a drop in battery voltage. (The latter applies only if the relevant control unit consisting of a sensor, a change-over switch  $COS_2$  and a receiver for the light from the charging unit (CLR) has been incorporated.)

When an obstacle is touched (OS closes) CF 1/2 sec. changes over to cry of fright and RM 3 sec. to reverse movement. CF 1/2 sec. starts the cry of fright by means of an oscillator (FO). RM 3 sec. switches the drive motor to position 'reverse' by means of a relay (RRL). CF 1/2 sec. also 'enables' the memory flip-flop (MFF) for half a second, i.e. it renders the flip-flop able to receive a triggering signal. The memory flip-flop (MFF) is switched on if within this time a pulse from the warning-sound receiver (WSR) reaches MFF. Once MFF has been set, a warning sound causes CF 1/2 sec. and RM 3 sec. to be activated via a

cybernetic

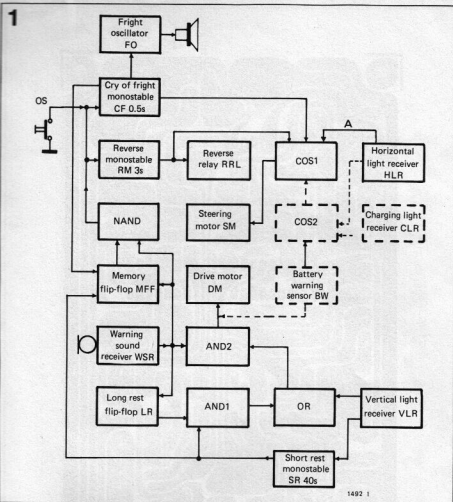
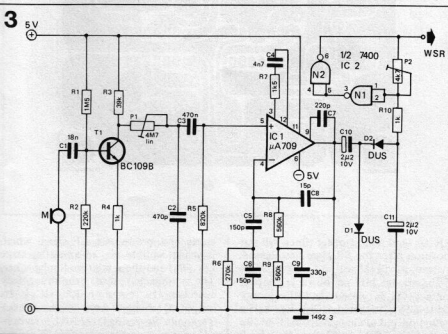
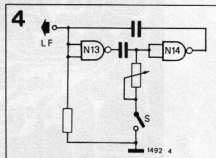
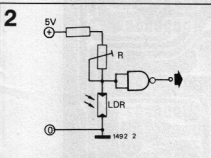

Figure 1. The block diagram shows the various 'sense organs' of the beetle; three light receivers (for vertical, horizontal and charging light), a warning-tone receiver and an impact contact for tactual stimuli. The information obtained from these organs affects the behaviour of the model via the motor, the steering motor and the reversing relay. A special sensor checks the operating voltage and ensures that the beetle makes for the 'food station' in time.

Figure 2. The circuit for the light receiver. Three of such receivers are required.

Figure 3. The warning-sound receiver.

Figure 4. Fright oscillator with two NAND's.



NAND network. This reaction is switched off by SR 40 sec., which resets MFF.

The light receiver for horizontal light (HLR) switches the steering wheel to its central position via a change-over switch (COS<sub>1</sub>) and the steering motor (SM). The change-over switch furthermore ensures that after the collision with the obstacle the reverse movement starts with a short turn.

If the automatic 'hunger sensation' is built in, connection A runs through change-over switch COS<sub>2</sub>. In this way it is ensured that at a given voltage the steering motor is no longer operated by the light receiver HLR, but by the light receiver for the charging unit CLR (via COS<sub>2</sub> and COS<sub>1</sub>).

### Light receivers

The circuitry of the three light receivers is identical (figure 2). Each consists of a NAND gate with a voltage divider consisting of two resistors and an LDR at the input. When illuminated, the LDR has a very low resistance, so that the NAND input is logically '0' and the output is logically '1'. In the absence of light, the resistance of the LDR is high. The NAND input is at positive potential and the output is at low potential (logically '0'). The LDR for vertical light (VLR) is mounted on the model's back. The output of the relevant receiver circuit controls the period of rest (SR 40 sec.). The LDR of the receiver for horizontal light (HLR) is accommodated in a black cylinder, approx. 10 cm long, together with a converging lens. In the model this 'viewing tube' is fitted horizontally and pointing forwards. If light from the light source reaches the LDR, the output of the receiver becomes logic '1'.

Via the change-over switch(es) (COS<sub>2</sub> and) COS<sub>1</sub> the receiver HLR controls the steering motor of the model.

The LDR of the receiver for the light from the charging unit must be screened from other light by means of a cylinder and, for instance, be fitted to the underside of the model so that only light from the charging unit can be received. Change-

# Cybernetic

over switch  $COS_2$  is controlled by the output of the charging light receiver CLR.

## The warning receiver WSR

To prevent the beetle from reacting to any arbitrary external noise, the receiver must be selective. The 'clap sensor' of figure 3 is eminently suitable. It consists of a preamplifier ( $T_1$ ), a selective amplifier with twin-T network ( $IC_1$ ), a rectifier circuit ( $D_1, D_2$ ) and a trigger circuit ( $N_1, N_2$ ). In the digital part of the model (figure 5) the output of the trigger is followed by a one-shot ( $IC_{12}$ ) set by clapping once. This one-shot can be considered as part of the receiver WSR in figure 1.

## The fright oscillator FO

An astable multivibrator consisting of two NAND gates constitutes the fright oscillator (figure 4).

Switch S is the on/off switch. In the model the output of a one-shot replaces this switch. The LF output drives a low-power audio output stage.

## The complete circuit

The description from the behavioural pattern shows that the model may move when sufficient light falls from above. In the absence of vertical light the model may only move if the flip-flop LR for the period of rest is in position  $Q = '1'$  and if furthermore the circuit for the pause in the shade SR 40 sec. is reset ( $\bar{Q} = '1'$ ).

These two possibilities are checked by the AND circuit consisting of  $N_5$  and  $N_6$  ( $AND_1$ ) and the subsequent OR circuit ( $N_7, N_8$  and  $N_3$ ).

Furthermore the model may not move when the sound receiver WSR receives a signal which makes the  $\bar{Q}$  output a logic '0'. This condition is combined with the conditions previously mentioned by means of  $N_4$  ( $AND_2$ ). The output of  $N_4$  is only a logic '0' if the conditions for moving have been fulfilled and no warning sound is received, because only in that case are the two inputs of  $N_4$  logically '1' and the output logically '0'.

The flip-flop for a prolonged period of rest LR is tripped by output  $\bar{Q}$  of the warning sound receiver ( $IC_{12}$ ) at every clap. For this reason the model will sometimes rest for the normal period

(SR 40 sec.) and at other times will not move on after the SR time has elapsed. Instead, it will fall asleep.

If the model hits an obstacle, impact contact OS is closed, and the monostable CF is triggered ( $IC_1$ ). For half a second output  $\bar{Q}$  changes from '1' to '0', so that the fright oscillator ( $N_{13}, N_{14}$ )

starts and produces a LF signal which is made audible via an amplifier stage ( $T_1, T_2$ ) and the miniature loudspeaker. The 'impact pulse' simultaneously switches the one-shot RM ( $IC_2$ ). Its output Q changes from '0' to '1' for 3 seconds. Reversing relay RRL is switched on via a power amplifier ( $T_3$ ); the

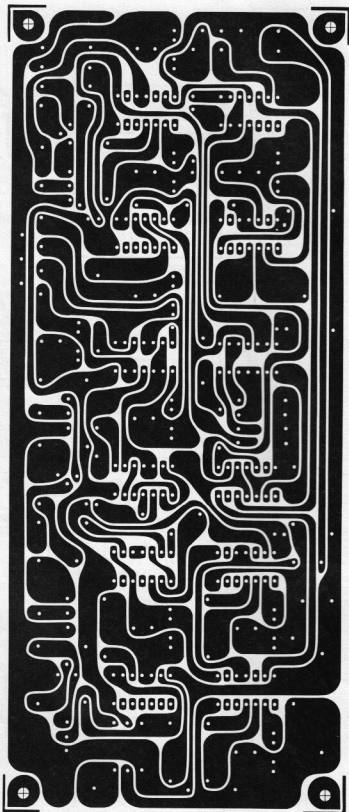

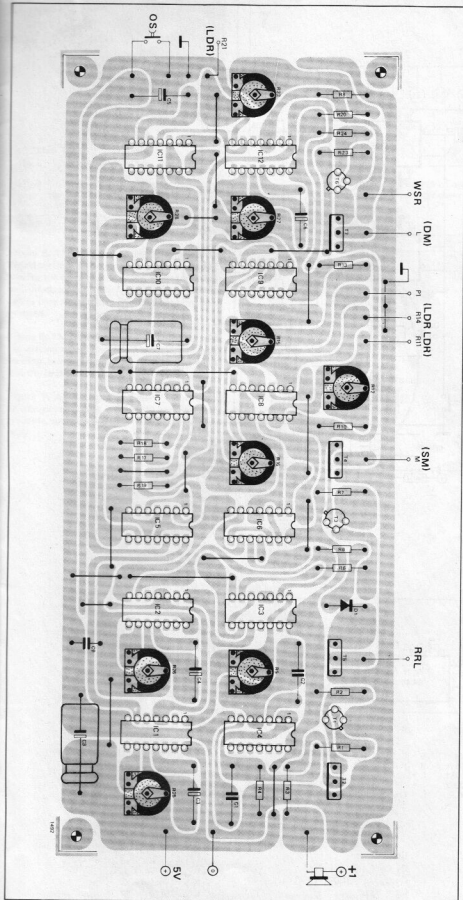

model moves backwards for approx. 3 seconds and thus moves away from the obstacle. The Q output of CF and the Q output of RM control gate  $N_9$  in change-over switch COS<sub>1</sub>. During forward movement the inputs of  $N_9$  are at '1' and '0', so that the output is logically '1'. As the input of  $N_{10}$  controlled by

RM is at '1' in this case, the steering motor is switched on (straight ahead), via  $N_{11}$ ,  $T_3$  and  $T_4$ , if the second input of  $N_{10}$  is also logically '1' and conversely. The signal to this second input does not affect the steering however, during the reverse movement for 3 seconds because the Q output of RM is '0'. This means

that the reverse movement is started with a turn (0.5 sec., determined by CF via  $N_9$ ), after which the movement is continued in a straight line backwards for another 2.5 sec. Then the relay lets go and the model starts moving forward again in a circle.

The memory flip-flop (MFF, IC<sub>5</sub>) has an input J connected to the Q output of CF. Every collision causes J to become '1' for 0.5 sec. If within this time a warning sound is heard the output Q of MFF changes to '1'. Consequently a negative pulse occurs at the output of  $N_{12}$  every time a clap is heard, which causes the cry of fright and the reverse movement even without a collision occurring (reflex). When the beetle rests in the shade MFF is reset via the 'clear' input ( $Q = '0'$ ). The memory has now been erased, so that a warning sound can only change over LR and cause the model to stop briefly (via  $N_4$ ).

As the time available for the reception of information by MFF is fairly short (0.5 sec.), it is often difficult to set the flip-flop by means of clapping. This is similar to a normal learning procedure, where it may also happen that only the second or even third combination of a warning sound together with the collision results in the desired reaction.

The circuit for a rest in the shade SR also comprises a one-shot (IC<sub>10</sub>) which in this case is controlled by the receiver for vertical light VLR via gate  $N_1$ . The motor is stopped for 40 sec. via  $N_5 \dots N_7$ ,  $N_3$ ,  $N_4$  and  $N_2$ , provided that meanwhile the model does not receive any light from above. The circuit for 'hunger' comprises among other things a threshold-value detector consisting of  $P_1$  and  $N_{16}$ .  $P_1$  can be set so that the input of  $N_{16}$  becomes logically '0' if the operating voltage has dropped to such a level that the accumulator must be recharged or the battery must be renewed. There must be sufficient energy left, however, to enable the beetle to reach the 'food station'. Because the life of the beetle is in danger when the voltage drops, protective functions, such as rest and panic stop are of secondary concern and are therefore cut out. The motor runs constantly via  $N_{15}$  and  $N_2$ .

The output of  $N_{18}$  (in COS<sub>2</sub>) is '1', whether there is horizontal light or not. As long as no collision occurs, only the receiver for the charging light (CLR) affects the steering motor via the input of gate  $N_{10}$  controlled by  $N_{20}$ . A collision is dealt with as usual; the effect of CLR is then cut out for 3 seconds.

### The mechanical construction

A commercially-available servomotor (max. 3 V) for model planes is eminently suitable as a steering mechanism. The motor must automatically return to its central or zero position. Building-in should be done at the front of the model, on the centre-line of the bottom plate (see figure 6). The motor must be fitted with approximately 20° slant to the left, so that the model describes a left turn



# Cybernetic

Figure 5. The complete circuit diagram of the digital section. As no particular types are specified for the drive motor, steering motor, relays and loudspeaker, the indications of voltage values near the positive connections have been omitted.

Figure 6. The position of the drive motor with the driving wheel and the free-running wheel, steering motor complete with steering wheel and the impact contact.

Figure 7. An example of a supply unit based on components that are usually commercially available, such as a 6-V drive motor and turning relay.

7

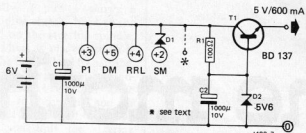

D1 = e.g. ZX3.9 (1 W), with adequate cooling if drivemotor draws more than 250mA.

6

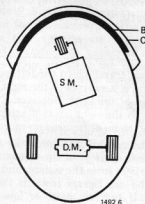

when the rear wheels are driven.

If a positive voltage is supplied to the base of the steering transistor ( $T_4$ ), this transistor conducts; the collector current passing through the steering motor pulls the steering wheel straight. If the model loses 'sight' of its target, the steering transistor is cut-off, the steering motor together with the steering wheel returns to the neutral position, which means turning in a circle.

The drive motor used is a commercially-available toy motor with reduction gearing. A low current consumption is a criterion for the choice of motor. The model must move slowly, approx. 10 cm/sec. Only the right-hand rear wheel is driven, the left-hand wheel rotating freely round its axle. The diameter of the wheels is 5-6 cm (model-plane wheels). The base plate is oval and approximately 30 cm long (figure 6). A metal strip B, approximately 1 cm high is fixed to the front of the base plate, and subsequently a bent piece of wire (C) is fitted in front of the strip. B and C together constitute impact contact OS. The metal strip and wire must be bent around the front of the model over such a distance that the impact contact also functions when the model hits an obstacle at an angle.

## Current supply

Because the most common and highest voltage in the circuit is 6 V, the design was based on a 6-V battery. The drive motor, the turning relay and the l.f. amplifier for the warning sound also operate at a voltage of 6 V, so that no problems will occur.

The voltage for the steering motor is usually lower. This voltage depends on the type of motor used. If it is rated at 2.4 V, for instance, a 3.9-V series voltage-reference diode ensures that the correct voltage is available for the steering motor. A simple 5 V stabilised supply is incorporated for the rest of the circuit. Capacitors  $C_8$  and  $C_9$  (figure 5) are included for suppression of possible interference pulses originating from the drive motor, the steering motor and the reversing relay.

M. Keul, H. Löh

# the moth

This is a design for a simple cybernetic model, based on an electric toy car, that will be attracted towards a light source like a moth, negotiating obstacles in its path.

The car has two motors, one to propel it and one for the steering mechanism.

The principle is quite simple. A light-sensitive element is mounted obliquely to the right at the front of the car.

Normally the steering motor keeps the car on a left turn, but this motor can be reversed by a relay, so that the car turns to the right. This happens each time the light-sensitive element receives light.

If the car, travelling to the left, passes a light source, it swerves to the right in the direction of the light. However, it keeps turning to the right, so that after some time the element receives no more light.

Then the car will automatically swerve to the left again until the element again receives light from the source, and so on. Thus the car zigzags towards the light source. It behaves more or less like a moth, hence the name of this apparatus.

## The circuit

The light-sensitive element used here is an LDR placed in a cardboard tube. This tube must be about 3 ... 5 cm long to screen off the daylight. Via an amplifier consisting of  $T_1$  and  $T_2$  (figure 2), the LDR drives a relay  $Re_1$  which reverses the steering motor  $M_1$ .

$P_1$  serves to adjust the sensitivity of the car. That is to say, it determines how far the car will swerve to the left or the right on its way to the light.

In this circuit the moth will hardly ever reach the light source because in a furnished room it will usually collide against a wall, chair, table or something else, and come to a standstill there. So it must be able to avoid an obstruction, an idea which is not so difficult to realize. For that purpose a mercury switch is fitted to the car chassis in such a manner that the contact just remains open. Now if the car collides, the mercury moves about in its tube with the result that the contact is closed momentarily (figure 3).

In the circuit diagram  $S_2$  is the mercury switch. Via this switch  $C_1$  is charged rapidly and then slowly discharges again. Thus the short pulse from the switch is artificially lengthened. As long as  $C_1$  has a potential greater than 0.7 V,  $T_3$  is turned on so that relay  $Re_2$  is energized for a few seconds. This energizing time can be varied by means of  $P_2$ .

The second relay has two functions.

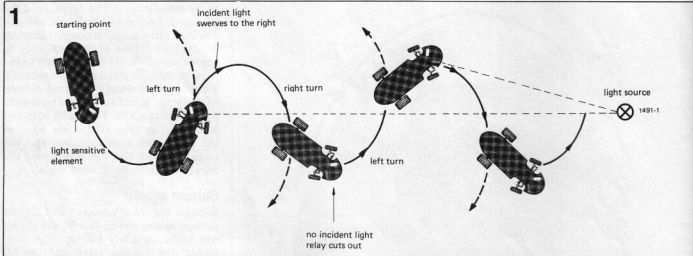

## Parts list

### Resistors:

- $R_1 = 22 \text{ k}$
- $R_2, R_3, R_6 = 10 \text{ k}$
- $R_4 = 22 \Omega$
- $R_5 = 47 \text{ k}$
- $R_7 = \text{LDR } 03, \text{ ORP12}$
- $P_1 = 220 \text{ k lin.}$
- $P_2 = 22 \text{ k lin.}$

### Semiconductors:

- $T_1 = \text{TUN}$
- $T_2 = \text{TUP}$
- $D_1, D_2 = \text{DUS}$

### Miscellaneous:

- $M_1 = \text{steering motor}$
- $M_2 = \text{drive motor}$
- $S_1 = \text{switch, } 2 \times \text{ make}$
- $S_2 = \text{mercury switch}$
- $Re_1, Re_2 = \text{relay } 6 \text{ V, coil resistance about } 200 \text{ ohms}$

## 2

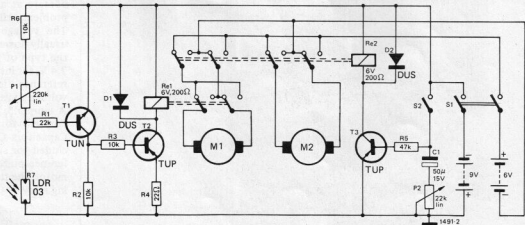

### Capacitors:

- $C_1 = 47 \mu\text{F}/16 \text{ V}$

Firstly it reverses the drive motor so that the car backs away from the obstruction. That alone would, however, not be sufficient, for if the car were then to start forward again, it would hit the obstruction a second time, and so on.

It is, therefore, also necessary that when the car backs away, the steering wheel be turned in the opposite direction in order to avoid the obstruction. So the second function of  $Re_2$  is to reverse the steering motor. Thus the motor is controlled in two ways: by the optical circuit (via  $Re_1$ ) and by the mercury switch (via  $Re_2$ ). Now the moth will always reach the light source, provided there is a road.

### The mechanical part

Electric toy cars that can be remotely controlled by a cable make ideal basic material.

The authors used an old lorry; the drive motor remained as it was, and a smaller motor was mounted at the front. On the spindle to which originally the remote control wire was connected, a pulley from a construction kit was mounted; another pulley was mounted on the motor shaft. Then these two were connected with a rubber drive belt.

It was found that it is better to drive steering mechanism via a slipping clutch. If the motor engaged directly with the steering mechanism, it would remain stalled most of the time because the

steering circuit is limited on both left and right.

As a result, current consumption would rise substantially. Figure 4 shows a home-made slipping clutch. Next to the wheel mounted on the steering spindle, a larger loose wheel is placed which is forced against the fixed wheel by a spring. First pieces of felt are glued to the contact faces of these wheels. The loose wheel is coupled to the motor and via friction of the felt between, it drives the bottom wheel and thus the steering circuit.

### The supply

Owing to the high current consumption of the motors, it is recommended that they be driven from an accumulator. A separate 9 V compact battery can thus be used for the electronics. The supplies of the two systems are separated to prevent interference generated by the motors from affecting the electronics. Should you find another motor suitable for the steering circuit but requiring a different supply voltage, a second accumulator will be needed.

The on/off switch can be of the three-pole type, and the two contacts controlled by  $Re_2$  can be supplied separately.

M. Ginolas

## micro-squeaker

This circuit is by way of being an electronic joke. The complete circuit comprises only one transistor, one capacitor, a miniature transformer and a headphone. The transistor can be any germanium type; the transformer can be any miniature type with a turns ratio between 3:1 and 10:1. At supply voltages as low as 0.2 V the headphone produces a distinct sound. Current consumption is then of the order of  $10\mu A$ , power consumption is less than  $2\mu W$ . The joke of this microsqueaker is that it is not fed from a 'normal' current source, but that the gifts of nature are called upon. The positive connection is a piece of bare copper wire, the negative connection is a bare piece of steel or silver wire. If both ends are stuck into an apple, a lemon or a potato, at some distance from each other, the apparatus produces a tone. A solar cell could also serve as the voltage source. The squeaker may also be used as an indicator for D.C. voltages in the range of 0.2 V ... 10 V.

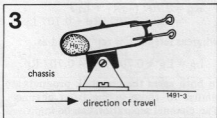
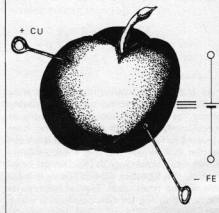
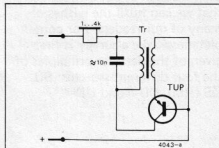
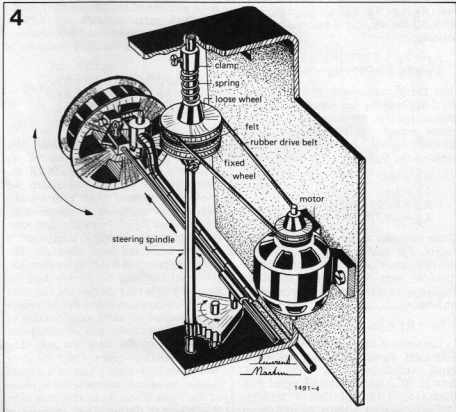

Figure 1. The course the car must follow to arrive at the light source if there are no obstructions.

Figure 2. The complete electronic circuit of the car.

Figure 3. The principle of the mercury switch.

Figure 4. The steering mechanism of the car.





# quadro in practice

In response to an earlier article on quadrophony ('Quadro 1-2-3-4 ...', December 1974), we received many requests for the complete circuit of a quadrophony decoder — preferably one which is suitable for all systems. However, the problem here is that the patentees for QS and CD-4 will not consent to the ICs developed for their systems being supplied by the retail trade\*. They are only to be supplied to original equipment manufacturers.

As a result, a home-made quadro decoder will have to consist of discrete components, so that it becomes far more complex than would otherwise be necessary. Nippon Columbia has now put such a design at our disposal, so that we can fulfil the wishes of many of our readers. For completeness' sake a survey is first given of the decoder principles of the four different systems: SQ, QS (RM), CD-4 and UD-4.

For a good understanding of quadrophony decoders in general, and of the decoder described here in particular, it is necessary to know something about the theory of the various systems. Therefore the systems SQ, QS, CD-4 and UD-4 are first dealt with in this article. For a description of the results that can be obtained with the various systems, the reader is referred to the above-mentioned article 'Quadro 1-2-3-4 ...'.

## SQ

This system (by CBS) is a 4-2-4 matrix system, that is to say, that the four original channels ( $R_F$ ,  $L_F$ ,  $R_B$ ,  $L_B$ ) are combined in a matrix ('encoder') to two channels for transmission ( $R_T$  and  $L_T$ ), where 'T' can be translated as 'transmission', and then separated again in a second (decoder) matrix into four channels ( $R_F$ ,  $L_F$ ,  $R_B$ ,  $L_B$ ) for reproduction. With SQ the encoder is described by the formula:

$$\begin{aligned} R_T &= R_F + 0.707(jR_B - L_B), \text{ and} \\ L_T &= L_F + 0.707(R_B - jL_B). \end{aligned}$$

Here the 'j' corresponds to a 90° phase shift.  $R_T$  and  $L_T$  are signals which are transmitted via, for example, a gramophone record; for reproduction, four different signals must be derived from them via the following formulae:

$$\begin{aligned} R_F &= R_T, \\ L_F &= L_T, \\ R_B &= 0.707(-jR_T + L_T), \\ L_B &= -0.707(jL_T + R_T). \end{aligned}$$

These formulae define the SQ decoding matrix. For completeness' sake we can also calculate what the four reproduction channels have in common with the original four channels. For front-right we have:

$$R_F = R_T = R_F + 0.707(jR_B - L_B).$$

So this signal is composed of the original front-right signal ( $R_F$ ), the right-back signal attenuated 3 dB and shifted through 90°, and the left-back signal also attenuated 3 dB and shifted through 180°. In the same manner it can be seen

that the signal reproduced left-front also consists of a mixture of three signals: the original left-front signal, and in addition the original left-back signal attenuated 3 dB and shifted through 270° (-j), and the original right-back signal attenuated 3 dB and in phase. Expressed in formula:

$$L_F = L_T = L_F + 0.707(R_B - jL_B).$$

The signal reproduced at the right-back is:

$$\begin{aligned} R_B &= 0.707(-jR_T + L_T) \\ &= R_B - 0.707jR_F + 0.707L_F, \end{aligned}$$

whereas left-back is reproduced as

$$L_B = L_R + 0.707jL_F - 0.707R_F.$$

In both cases the crosstalk products are similar to those in the front channels. The channel separation can be improved by using two approaches. The simplest is the addition of two resistors, by means of which extra crosstalk, say 10%, is introduced between the front channels and 40% between the back channels. In formula:

$$\begin{aligned} R_F' &= 0.9 R_F + 0.1 L_F, \\ L_F' &= 0.9 L_F + 0.1 R_F, \\ R_B' &= 0.6 R_B + 0.4 L_B, \\ L_B' &= 0.6 L_B + 0.4 R_B. \end{aligned}$$

Other 'blend' ratios are also used. This decrease of channel separation at the front and back results in a 6 dB improvement of channel separation between 'centre-front' and 'centre-back'. The second approach is the so-called 'gain-control logic'. In its simplest form this consists of automatic level controls for the front and back channels. The operating principle is that if, for example, the front channels are louder than the back channels (in other words, the main sound sources are at front) the difference is emphasized by extra amplification of the front channels and simultaneous attenuation of the back channels. The more expensive version ('full logic' or 'wave-matching logic') can in a similar manner boost one channel at the expense of the other three. So in that case only the left-front channel, for example, is

\* It is extremely difficult to write a truly up-to-date article on the subject of quadrophony, as new information is pouring in continuously. Although this article has been up-dated as far as possible (the first draft was written in February ...), it is already slightly out-of-date: according to our latest information, the Signetics CD4-392 is now available via the retail trade. Elektor laboratories are now studying the new possibilities which this offers.

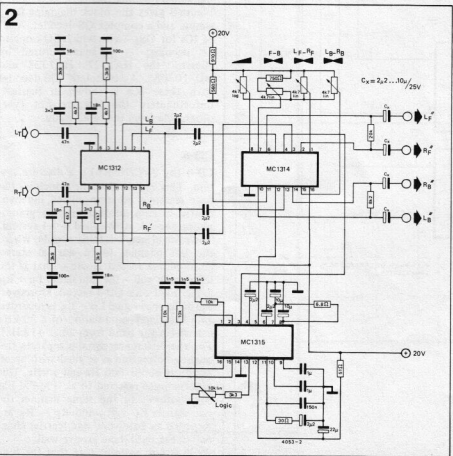
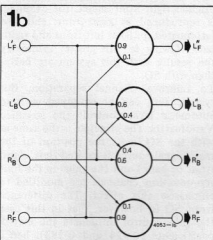
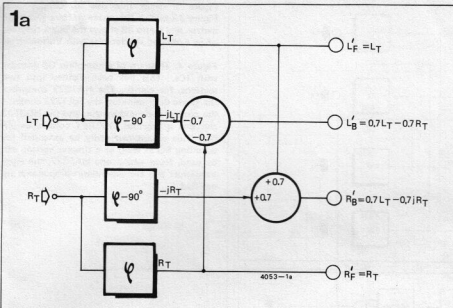

**Figure 1.** Block diagram for an SQ decoder. The basic decoder corresponds to figure 1A. The phase shifters are so designed that within the audio band there is an almost constant mutual phase difference of  $90^\circ$  (corresponding to  $\pm j$ ) between the two pairs of output signals. Figure 1B gives an addition (so-called blend), with which the channel separation front-back and along the diagonals can be improved at the expense of the channel separation left-right. Alternatively, 'logic' (figure 1C) can be used, for the same purpose.

**Figure 2.** The diagram of a complete SQ decoder with 'logic'. The MC1312 comprises the phase shifters and matrix, the MC1315 comprises the control circuits for full logic and drives the MC1314 which comprises the buffer amplifiers with gain control.

amplified whilst the other three channels are attenuated.

With suitable demonstration records this 'logic' can lead to an almost discrete reproduction of single channels. The block diagram of an SQ decoder is shown in figure 1. Motorola is one of the firms offering a complete series of ICs for an SQ decoder with full logic: the MC1312, MC1314 and MC1315. The first comprises the basic decoder (except for a number of resistors and capacitors!) whilst the other two contain variable-gain amplifiers and the full-logic control. A practical circuit with these ICs is given in figure 2. In contrast to the other ICs, these types can be obtained via the retail trade.

## QS

This system (by Sansui) is also a 4-2-4 matrix system. The matrix itself is standardised in Japan as RM (regular matrix), so that on universal decoders the QS position is sometimes indicated as 'RM'.

In this case the encoder is described by the formulae:

$$\begin{aligned} R_T &= 0.924(R_F - jR_B) + 0.383(L_F - jL_B), \text{ and} \\ L_T &= 0.924(L_F + jL_B) + 0.383(R_F + jR_B). \end{aligned}$$

The factors 0.924 and 0.383 are  $\cos 22\frac{1}{2}^\circ$  and  $\sin 22\frac{1}{2}^\circ$ , respectively. The decoder matrix is as follows:

$$\begin{aligned} R_F &= 0.924 R_T + 0.383 L_T, \\ L_F &= 0.924 L_T + 0.383 R_T, \\ L_B &= -0.924 jL_T + 0.383 jR_T, \text{ and} \\ R_B &= 0.924 jR_T - 0.383 jL_T. \end{aligned}$$

After some calculation we find that for reproduction the output signals are composed as follows:

$$\begin{aligned} R_F &= R_F + 0.707 L_F - 0.707 jR_B, \\ L_F &= L_F + 0.707 R_F + 0.707 jL_B, \\ L_B &= L_B + 0.707 R_B - 0.707 jL_F, \text{ and} \\ R_B &= R_B + 0.707 L_B + 0.707 jR_F. \end{aligned}$$

In contrast to the results obtained with SQ, crosstalk is almost symmetrical: the



4

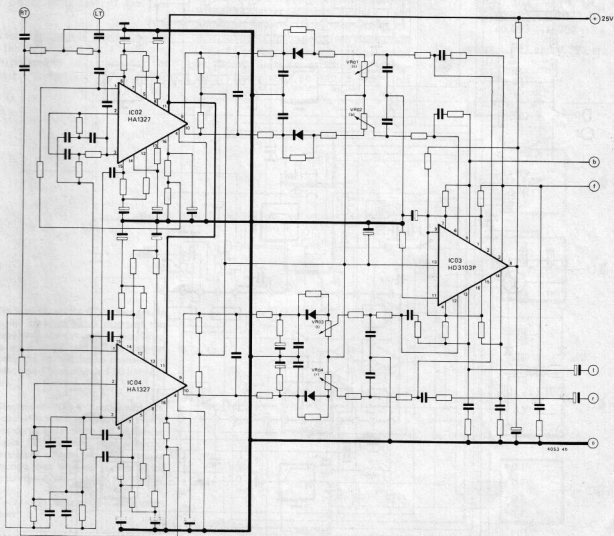
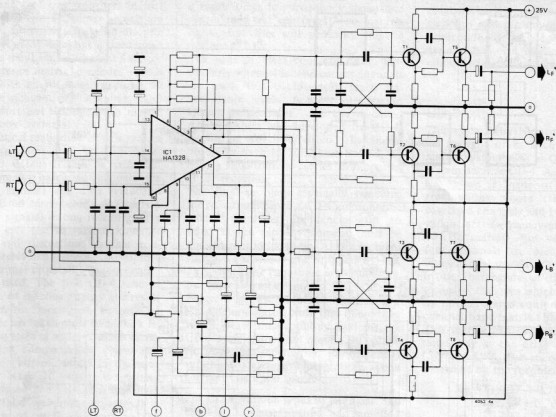

5

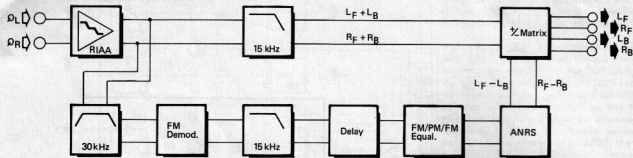

4053-5

6

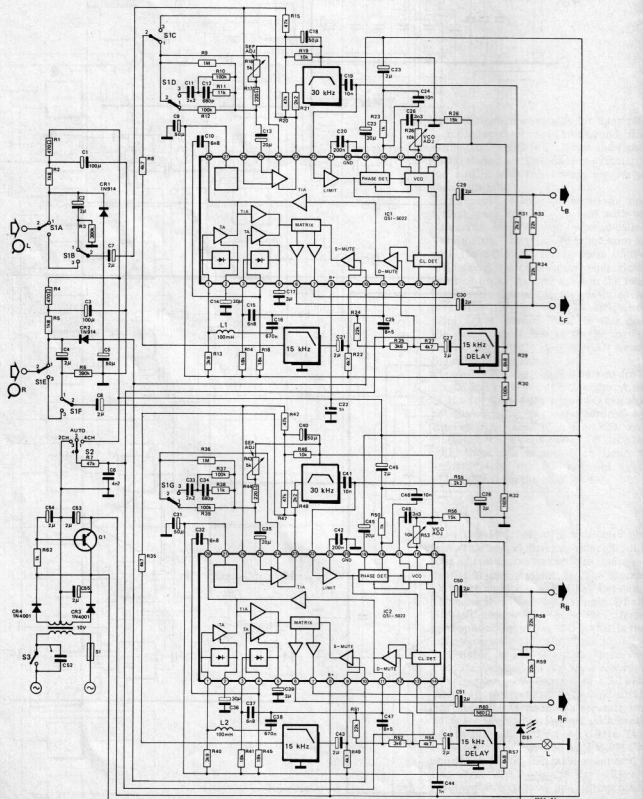

channels  $L_F$ ,  $L_B$ ,  $R_F$ ,  $R_B$  are transmitted independently of one another: in fact two sum and two difference signals are used. This does not affect the discrete character of the system, but it does mean that in the playback equipment a simple 'sum-difference matrix' is needed - as is the case with an FM-stereo decoder. In spite of the inclusion of this matrix, CD-4 certainly does not belong to the 'matrix quadrophony' systems!

In the practical realisation of this system the real problems crop up ... Without going into details it can be said that transmitting two baseband channels (the two sum signals) and two wideband FM-modulated carrier channels (the two difference signals) in one record groove can easily give rise to various kinds of crosstalk and distortion; in this connection phrases like 'uptalk', 'downtalk', 'carrier-channel crosstalk', 'energy spill', et al. are used. The first CD-4 records were often of inferior quality as a result of this. In the meantime, however, a change-over has taken place to a 'Mark II' recording system in which various forms of distortion compensation (Neutrex I and II) are built in, whilst in the near future the 'Mark III' version is to come into operation. The fact that this gives designers (and recording studios?) a headache is of no importance to the consumer; what is important is that the quality of the newer CD-4 records is indeed far better than that of the first ones.

To 'protect' the carrier channels even further, the later equipment also contains the possibility of suppressing the low-frequency components of the differ-

ence signals ( $L_F - L_B$  and  $R_F - R_B$ ). As a result these low-frequency signals are reproduced as 'centre-left' or 'centre-right', but this will generally not be noticed.

The next problem concerns noise. Particularly when wideband carrier channels are used, this could easily reach unacceptable levels. A noise suppression system is desirable, and the so-called ANRS system was developed for CD-4. According to JVC/Nivico, the initial problems have by now been solved, by adding an automatic carrier level control at the recording end.

The final problem especially concerns the consumer. Since a CD-4 gramophone record contains frequencies up to 45 kHz, the pick-up element must be able to reproduce these. At the moment suitable cartridges are supplied by a.o. JVC, National Panasonic and Pickering, but they are not cheap.

Figure 5 shows the block diagram of a CD-4 demodulator. Note that in contrast to all other quadrophony systems the CD-4 system does not require 90° phase shifters. This means that the system is suitable for extensive integration, which can save costs and space.

For CD-4, various types of ICs exist: the CD-4 392, manufactured and supplied by Signetics, and the QSI 5022 supplied by Quadracast Systems Inc. The factory application for a complete CD-4 decoder with the latter IC has already been published several times. For completeness' sake this diagram is given once again (figure 6); the necessary low-pass and band-pass filters are supplied by Matsushita. It should be noted that this

circuit includes the preamplifiers for magnetic cartridges, as well as changeover switches and biasing arrangements for semiconductor cartridges. These circuits are not included in the SQ and QS decoder designs shown previously.

#### UD-4

This system (by Nippon Columbia) can be thought of as a combination of a matrix system such as QS and a discrete system such as CD-4. As is the case with CD-4, use is made of a four-channel gramophone record (the normal two baseband channels and two sub-channels which are frequency-modulated on a 30 kHz carrier), but with UD-4 these four channels are used to transmit a four-channel matrix.

In the basebands of the gramophone record - the ones which are reproduced by normal stereo equipment - the two-channel basic matrix (BMX) is recorded. This matrix can first be treated in the same way as the other matrix systems (SQ and QS). The encoder for BMX is described by the formulae:

$$R_T = (1.707 - 0.707 j)R_F + (1.707 + 0.707 j)R_B + (0.293 - 0.707 j)L_F + (0.293 + 0.707 j)L_B;$$

$$L_T = (1.707 + 0.707 j)L_F + (1.707 - 0.707 j)L_B + (0.293 + 0.707 j)R_F + (0.293 - 0.707 j)R_B.$$

The factors 1.707 and 0.293 are  $1 + \frac{1}{\sqrt{2}}$  and  $1 - \frac{1}{\sqrt{2}}$  respectively.

Figure 5. Block diagram of a CD-4 decoder. In contrast to the previous block diagrams this diagram also shows the dynamic preamplifier. This forms an essential part of the decoder since not only the normal stereo channels are used, but also two FM-modulated 30 kHz carrier channels.

Figure 6. Diagram of a CD-4 decoder with ICs. The input circuit is more complicated than is strictly necessary, because it has also been made suitable for the new semiconductor pick-up cartridges. These do not require RIAA correction, but they do require a bias current; furthermore, the outputs are in anti-phase.

The ICs are only supplied to original equipment manufacturers.

Figure 7. Block diagram of a simple UD-4 decoder, suitable only for BMX.

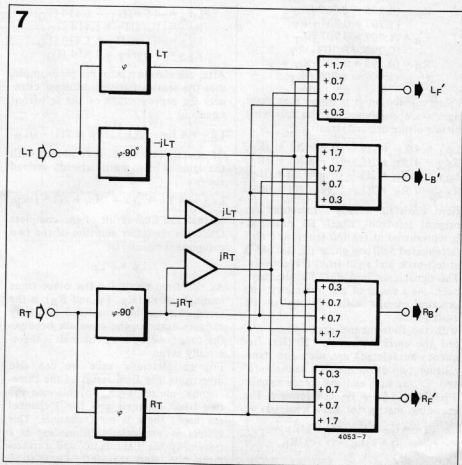

8

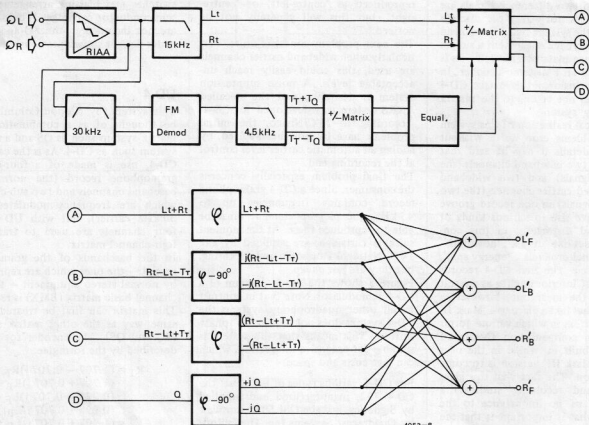

The decoder matrix for BMX is as follows:

$$\begin{aligned} L'_F &= (1.707 - 0.707 j)L_T + (0.293 + 0.707 j)R_T, \\ R'_F &= (0.293 - 0.707 j)L_T + (1.707 + 0.707 j)R_T, \\ L'_B &= (1.707 + 0.707 j)L_T + (0.293 - 0.707 j)R_T, \\ R'_B &= (0.293 + 0.707 j)L_T + (1.707 - 0.707 j)R_T. \end{aligned}$$

From calculation it is found that these signals are composed of the following blends of the original signals:

$$\begin{aligned} L'_{F,1} &= 4 L_F + 2(1-j)L_B + 2(1+j)R_F, \\ R'_{F,1} &= 4 R_F + 2(1-j)L_F + 2(1+j)R_B, \\ L'_{B,1} &= 4 R_B + 2(1-j)R_B + 2(1+j)L_F, \\ R'_{B,1} &= 4 R_B + 2(1-j)R_F + 2(1+j)L_B. \end{aligned}$$

Here, crosstalk is fully symmetric: the original left-front signal, for example, is reproduced at the left-front, and also (attenuated 3 dB and phase shifted  $\pm 45^\circ$ ) at left-back and right-front respectively. This signal is not reproduced at the right-back. As a result of this symmetry, the practical results with this matrix are quite good.

With the four-channel gramophone record the carrier channels (30 kHz, frequency-modulated) are used for transmitting two extra matrix channels, 'T' and 'Q', as sum and difference signals:  $T_T + T_Q$  and  $T_T - T_Q$ , respectively. The encoding matrix for these channels is:

$$\begin{aligned} T_T &= (j-1)L_F + (j+1)R_F - \\ & \quad (j+1)L_B - (j-1)R_B, \end{aligned}$$

and

$$\begin{aligned} T_Q &= 1.414 jL_F - 1.414 jR_F - \\ & \quad 1.414 jL_B + 1.414 jR_B. \end{aligned}$$

The corresponding decoder matrix for these additional channels is:

$$\begin{aligned} L'_{F,2} &= -(1+j)T_T - 1.414 jT_Q, \\ R'_{F,2} &= (1-j)T_T + 1.414 jT_Q, \\ L'_{B,2} &= -(1-j)T_T + 1.414 jT_Q, \\ R'_{B,2} &= (1+j)T_T - 1.414 jT_Q. \end{aligned}$$

After calculation it is found, for example, that the result of these additional channels for reproduction of the left-front signals is:

$$L'_{F,2} = 4 L_F - 2(1+j)R_F - 2(1-j)L_B.$$

Of course, this signal is combined with the signal of basic matrix already derived above:

$$L'_{F,1} = 4 L_F + 2(1-j)L_B + 2(1+j)R_F,$$

so that the final result of the complete QMX matrix (after addition of the two component signals) is:

$$L'_F = 8 L_F.$$

As the final result for the other three original signals ( $R_F$ ,  $L_B$  and  $R_B$ ) is the same, this can be considered as a fully discrete system: the crosstalk between the four quadrophony channels is theoretically zero!

For completeness' sake we can also investigate the final result of the three-channel matrix TMX. In this case the two basic channels and the T channel are used; there is no Q channel. This system is particularly interesting as a possibility for 'FM-quadro' and, furthermore, the latest theories show that an

Figure 8. Block diagram of an extensive UD-4 decoder, suitable for the four-channel matrix (QMX). The first section can be compared with the CD-4 decoder, and also contains the dynamic preamplifiers; the second section comprises the phase shifters and matrix. To economise on phase shifters and matrix, L, R, T and Q are not routed through separate phase shifters (in that case eight of these would be needed); instead the blend signals  $L+R$ ,  $R-L-T$ ,  $R-L+T$  and Q are formed first, so that four phase shifters are sufficient.

Figure 9. No ICs are available for UD-4 as yet. However, starting from imaginary ICs (derived from existing types, designed for other systems) this diagram has been set up. It gives an impression of what a UD-4 decoder with ICs could look like. Even more thorough integration is conceivable: by integrating both input preamplifiers in IC1, sufficient room would be made available in IC2 to accommodate IC3.

optimal three-channel system is in fact inherently better than a four-channel system (used non-redundantly) for giving four-loudspeaker quadrophonic reproduction! The output signal of the left-front channel is then composed as follows:

$$L_F = 6 L_F + 2 L_B + 2 R_F - 2 R_B.$$

So channel separation is far from complete (about 12 dB), but owing to the

high degree of symmetry and the lack of phase shift in the final output, the practical results are particularly good. As regards the extra carrier channels, the practical problems encountered with UD-4 run parallel with those of CD-4. Here, however, a different solution has been found for the noise (and crosstalk) problem: the bandwidth of the  $T_T$  and  $T_Q$  channels is limited to about 6 kHz, so that above this frequency the system

is actually reduced to BMX. So localisation at high frequencies becomes less accurate, but this is hardly noticeable because the human ear itself is less directional at these frequencies.

To reduce low-frequency interference between the carrier channels (or to make matters even more complex?) the  $T_Q$  signal is attenuated with respect to  $T_T$  for lower frequencies. This means that the difference between the two carriers

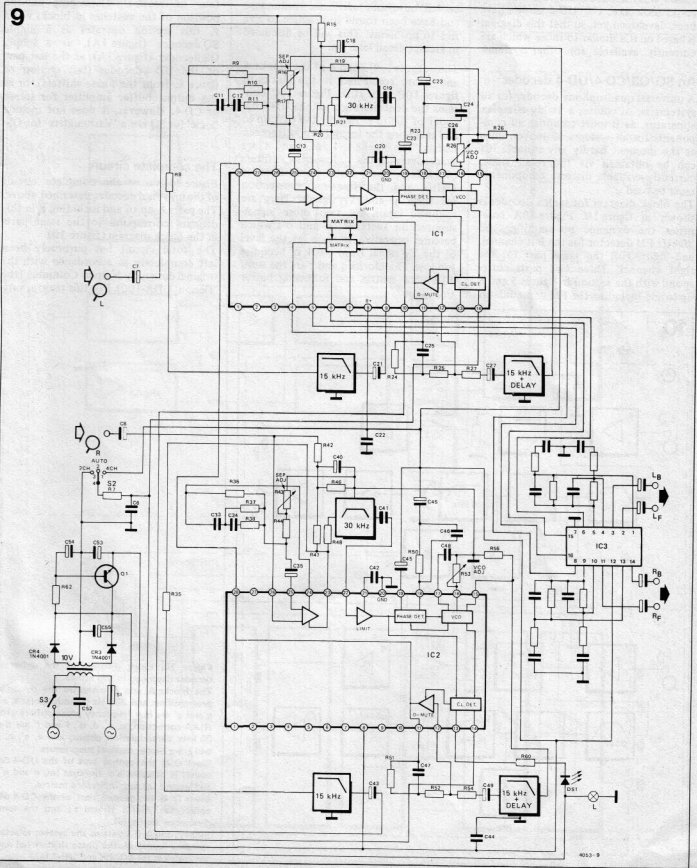



( $T_T + T_Q$  and  $T_T - T_Q$ , respectively) becomes less at lower frequencies, so that there is less chance of mixture products occurring. During playback the  $T_T$  and  $T_Q$  signals must therefore undergo different frequency corrections to restore them to equal levels. A block diagram for a simple UD-4 decoder (BMX only) is shown in figure 7, whilst figure 8 is the block diagram of a complete four-channel decoder for QMX. Figure 9 shows what a circuit diagram with ICs could look like. For UD-4 no ICs have been developed yet, so that this diagram is based on ICs similar to those which are currently available for other systems.

### An SQ/QS/CD-4/UD-4 decoder

A universal quadrophony decoder for all systems is, of course, a highly complex apparatus, as it must comprise all components for all systems. Moreover, since at the moment hardly any suitable ICs can be obtained via the retail trade, currently-available discrete components must be used ...

The block diagram for such a decoder is shown in figure 10. Figure 10A comprises the dynamic pre-amplifier and 30 kHz FM detector for the left channel, and figure 10B the same part for the right channel. These two parts correspond with the section in figures 5 and 8 up to and including the FM demodulator

in the carrier channels. In this case, however, the RIAA frequency correction is divided over two blocks, a and g (a' and g', respectively). Furthermore, a number of suppression switches for the carrier channels have been added (e, i, e' and i') which become operative as soon as the level of the left carrier channel becomes too low. They are driven via block h; this carrier signal detector also drives a pilot lamp. However, it should be noted that the switches e and e' can be left out: they are in fact redundant and have been found in practice to give rise to problems! This will be discussed in greater detail later on.

The outputs 1, 2, 3 and 4 of the blocks A and B are connected to the blocks in figures 10C and 10D. Figure 10C contains the centre section of the UD-4 decoder of figure 8, namely the part up to and including the second sum/difference matrix. The blocks 1', m, n and n' are successively the low-pass filters (4.5 kHz), the first sum/difference matrix and the frequency correction for the  $T_T$  and  $T_Q$  signals. They are followed again by two more signal-suppression switches (o and o') which become operative as soon as the level of the  $T_T$  signal from block o' becomes too low. The blocks q and r are the sum/difference matrix and following buffer amplifiers.

Figure 10D comprises the second part of the CD-4 decoder. (figure 5). The blocks s and s' contain the 15 kHz low-pass filters, delay circuits and FM/PM/FM frequency correction networks for the carrier channels.

Finally figure 10E contains the system selection switches, phase shifters and matrices for the four systems or stereo. So it is connected to the baseband channel outputs of blocks A and B, and also to the four outputs of block C and the four of block D. Depending on the position of the switches in blocks v and y, this section operates as a simple SQ decoder (figure 1A), as a simple QS decoder (figure 3A), as the last part of the UD-4 decoder (last section of figure 8, from the phase shifters), or as the output buffer amplifier for stereo or CD-4. However, it does not include 'logic' for SQ nor a 'Variomatrix' for QS.

### The complete circuit

Figure 11 shows the complete circuit of the universal decoder described above.

The parts A up to and including E in this diagram correspond to the same parts in the block diagram (figure 10).

The total circuit has purposely been left completely in accordance with the original design by Nippon Columbia (the 'Denon' UDA-100). For this reason, vari-

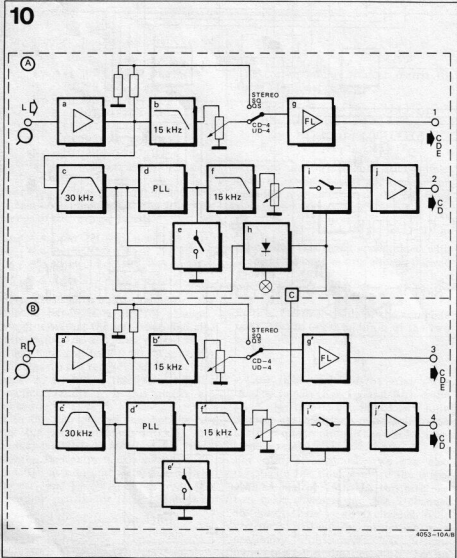

Figure 10. Block diagram of the universal decoder described in this article.

The blocks A and B comprise the dynamic preamplifiers and 30 kHz demodulators; a, a', g and g' are low frequency preamplifiers with RIAA correction; c, c', d, d', f and f' are the 30 kHz demodulation chains, and e, e', h, i and i' are carrier channel suppressors.

Block C is the central part of the UD-4 decoder; it contains a.o. the first (m, n and n') and second (q) sum-difference matrix.

Block D is the second part of the CD-4 decoder: the ANRS (t and t') and the sum-difference matrix (u).

Finally, block E contains the system selector switches (v and y), the phase shifters (w) and the matrices for SQ, QS and UD-4 (x).

ous resistors from the E-24 series occur in it. For the resistors and capacitors it is recommended that 5% types should be used. The choice of alternative semi-conductors is generally not critical. The transistors 2SC1000BL can be replaced by TUNs, the 2SC1000BL/CR, 2SC1000GR and 2SC1213 by BC 107B, the 2SC732GR by BC 109C and the 2SA493GR by BC 179B or C. The diodes can be replaced by DUSs, whilst for the FETs almost any type of N-channel FET is suitable (E 300, BF 245, etc.).

The ICs TA7122AP are low-noise differential amplifiers; when replacing these types by alternatives, the connections and some of the resistor values will, of course, have to be changed. For IC3 and IC6 two possible types are indicated: the NE565 (Signetics) and the HA1173, with slightly deviating resistance values. Various adjustment points are also indicated in the circuit (figure 11A/B). The trimmers near IC3 and IC6 (VR2 and VR5) serve for adjusting the centre frequency of the PLL (30 kHz). VR3 and

VR6 (near FET2 and FET4) set the level of the demodulated carrier channel separation for CD-4 and UD-4. The potentiometers ('B') in the output circuit of the first low-pass filters serve to adjust the level of the baseband channels; in principle, their function is the same as that of the adjustment resistors VR3 and VR6. Trimmer VR7 (near TR16/17) adjusts the trigger level of the suppression switches (blocks i and i'). In figure 10C only one trimmer occurs: VR5 (near TR26/27). This serves to ad-

## 10

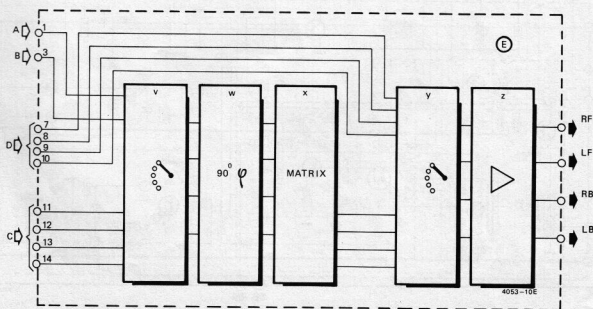
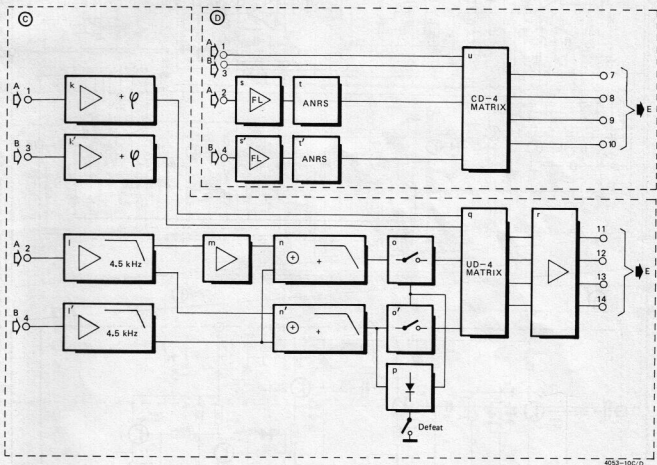

just the trigger level at which the suppression switches for the T and Q signals (blocks o and o') become operative. Finally, in block D there are four trimmers for adjusting the ANRS. VR1 and VR2 serve for zero adjustment: they set the control signal level at which the

ANRS begins to function. VR3 and VR4 adjust the ANRS control range; they also influence the zero setting mentioned above. Furthermore, it should be noted that the trimmers in the carrier channels (VR3 and VR6 in blocks A and B) also influence this zero setting.

### Final notes

As will be clear from what has been said above, the complete apparatus is not required for every system. For SQ and/or QS block E is sufficient; at the most an SQ logic with MC1314 and MC1315 (figure 2) or extra 'blend' resistors could

11

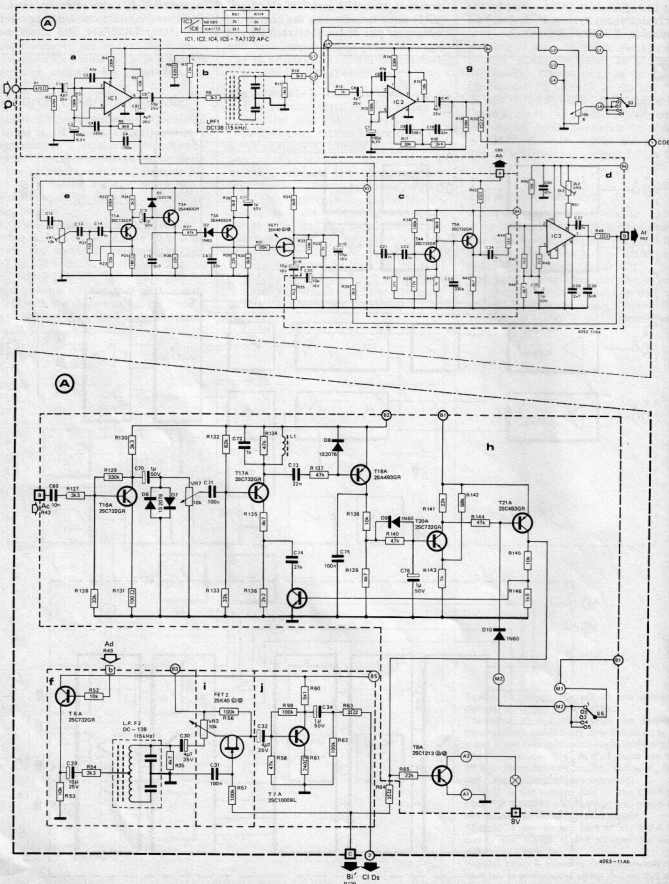
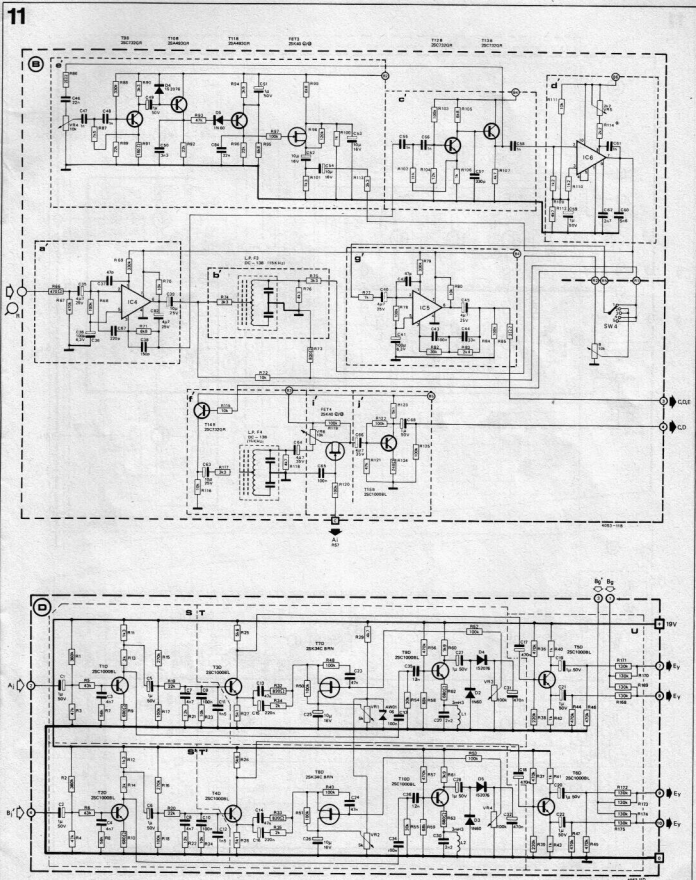

Figure 11. Complete diagram of the universal decoder. The blocks A up to and including E and the blocks a up to and including z correspond to the indications in the block diagram (figure 10). The blocks e and e' (in A and B) may be left out (see text). Replacement types for the semiconductors are indicated in the text.

be added and also a Variomatrix for QS. For the 'blend' resistors (see figure 1B) one can experiment with a resistor of about 68 k between the outputs  $L_F$  and  $R_F$  and a resistor of about 10 k between the outputs  $L_B$  and  $R_B$ . CD-4 requires the blocks A, B and D, in

combination with a simple CD-4/stereo switch and output amplifiers as in block E. For UD-4 only block D is redundant; if only UD-4 is required, the system selection switches can be simplified and various matrix resistors can be omitted from block E.



Finally it should be noted that two of the four signal suppression switches in blocks A and B can be left out. This concerns the part from C12 up to and including C18 (block e) and the part from R86 up to C52 (block e'). The resistor combinations R35/36 and R101/

113, respectively, can then each be replaced by one 4k7 resistor.

#### Literature:

*Quadro 1-2-3-4 ...: Elektor, December 1974, p. 33-37.*

*Proposed universal encoding standards for compatible four-channel mixing: R. Itoh, Journal of the Audio Engineering Society (JAES), April 1972, p. 167.*

*Discrete-matrix multichannel stereo: D.H. Cooper and T. Shiga, JAES, June*

11

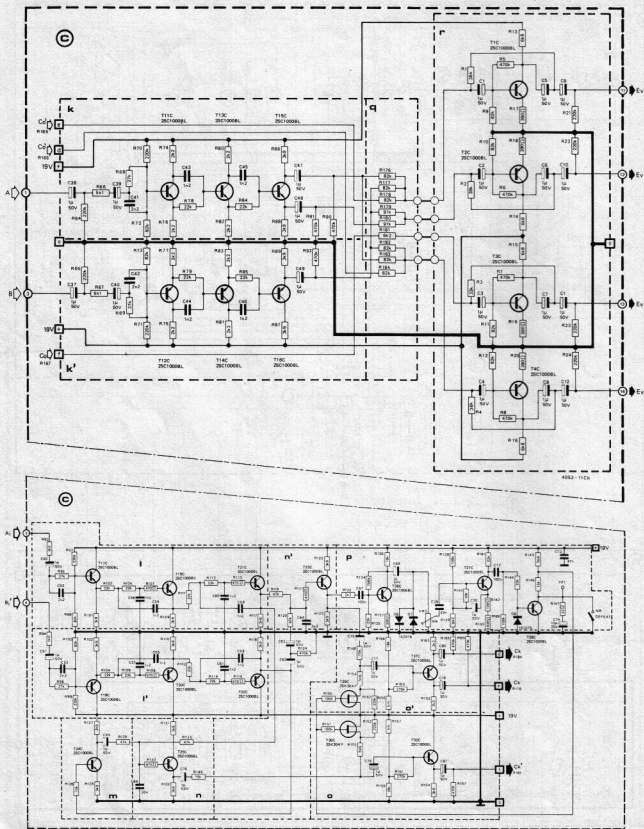

1972, p. 346 and July 1972, p. 493.

The Japanese Regular Matrix:

P.B. Felgett, Hi-Fi-News, Dec. 1972,

p. 2393.

SQ Matrix Quadrophonic Discs:

B.B. Bauer, G.A. Budelman and

D.W. Gravereaux, JAES, Jan. 1973,

p. 19.

The Principles and Performance of the

Sansui QS Variomatrix: S. Takahashi

and K. Hirano, JAES abstract,

Feb. 1973.

Discrete 4-channel records: W.R. Isom,

JAES abstract, Feb. 1973.

The CD-4 Mark-II Modulation System:

Y. Kokubun, S. Muramoto and J. Eargle,

JAES, July/August 1974, p. 416.

11

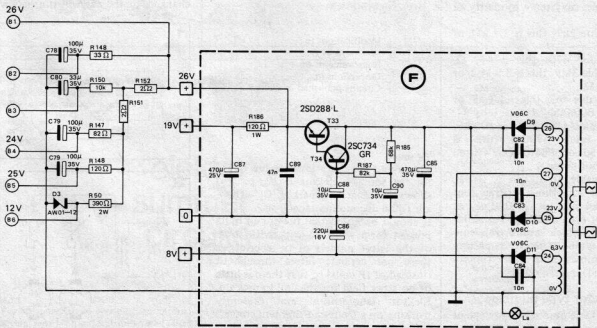
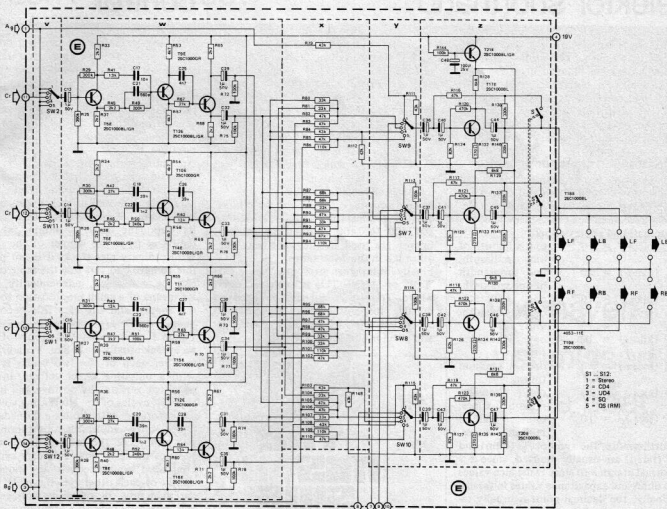

## elektor shorthand

From various enquiries it has become clear that some of our readers feel that they have been plunged in at the deep end. Elektor's 'shorthand' style of symbols and conventions seems to have led to some confusion, in spite of our efforts to the contrary, so some further explanation seems to be called for.

### Resistor and capacitor codes

When giving the values of resistors and capacitors, decimal points and large numbers of zeros are avoided as far as possible. To this end, extensive use is made of the international abbreviations:

p (pico-) = $10^{-12}$ = one millionth of one millionth;
n (nano-) = $10^{-9}$ = one thousandth of one millionth;
$\mu$ (micro-) = $10^{-6}$ = one millionth;
m (milli-) = $10^{-3}$ = one thousandth;
E = $10^0$ = unity;
k (kilo-) = $10^3$ = one thousand times;
M (mega-) = $10^6$ = one million times;
G (giga-) = $10^9$ = one thousand million times;
T (tera-) = $10^{12}$ = one million million times.

Furthermore, the symbols  $\Omega$  (ohm) and F (farad) are usually omitted, since it is normal practice to state resistance values in ohms and capacitance values in farads. Finally, the decimal point is usually replaced by one of the abbreviations (p, n,  $\mu$  ...) listed above (This has also been accepted practice for some years).

A few examples may serve to clarify all this:

Resistance value 2k7: this is 2.7 k $\Omega$ , or 2700  $\Omega$ .

Resistance value 470: this is 470  $\Omega$ .

Resistance value 3M9: this is 3.9 M $\Omega$ , or 3,900,000  $\Omega$ .

Capacitance value 4p7: this is 4.7 pF, or 0.000 000 000 004 7 F ...

Capacitance value 100  $\mu$ : this is 100  $\mu$ F.

Capacitance value 4700  $\mu$ : this is 4700  $\mu$ F, and could have been written as 4m7 — but never is.

Capacitance value 10 n: this is 10 nF, and is also sometimes written (but not in elektor!) as 10,000 pF or 0.01  $\mu$ F; or even as 10 kpF (10 kilopico-Farad), which is a horrible confusion of symbols. In the same way one sometimes finds  $\mu\mu$ F (micro-micro-Farad) instead of pF.

### Semiconductor type numbers

Very often, a large number of equivalent types for one integrated circuit exist with different type numbers. On closer exam-

ination, a group of digits are often found to be identical, but they are pre- or suffixed with letters and digits which denote the manufacturer. As an example, a popular op-amp is variously denoted as  $\mu$ A741, LM741, L741, MC1741, MIC741, RM741, SN72741 or ZLD741, to name a few. To cut through this confusion, this IC is referred to in elektor as a '741' — which means that we couldn't care less who makes it, provided it meets the specifications...

In the same way, '7400' (or sometimes even '00') stands for SN7400, SN74H00, DM7400, MC7400, etc., and the last two figures are used in the same way for other ICs in the 7400 series.

Finally, transistors are sometimes listed 'TUP' or 'TUN'. This is explained elsewhere. Transistors can also be listed as BC107, for instance; a long list of equivalent types for the BC107 series is also given in the TUP/TUN list.

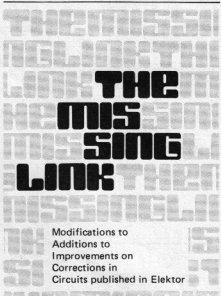

Modifications to  
Additions to  
Improvements on  
Corrections in  
Circuits published in Elektor

### TV sound

The layout for the printed circuit board for 'tv sound' (elektor no. 2, p. 236) shows two capacitors marked 'C<sub>x</sub>'. These are 100 nF decoupling capacitors.

It should be noted that the circuit in its present form will not work with some of the latest models of tv receiver, as these use ceramic filters throughout (instead of IF coils) so that there is little or no stray field for the coil to pick up. Elektor laboratories are presently working on a front-end that will convert this design into an entirely independent receiver for tv sound.

### E. Waschkowski

## sniff race control

With many model car race-tracks the circuit consists of two concentric tracks, so the inside track is always shorter than the outside track. A widely employed method to have both race-cars still cover the same distance is to constantly switch them from the inside to the outside track and back again by means of cross points.

An entirely different approach is the so-called sniff race. During this race the two cars follow the same track. The cars start with half a track distance between them. The car that catches up with its opponent until it bumps into it (sniffs at it) is the winner of the race. With ordinary race-tracks it is not possible to have two cars ride the same track and be controlled independently, but by means of a small modification to the d.c. supply and the cars this becomes possible.

Figure 1 shows what the supply of the race-track usually looks like. Via a bridge rectifier each of the two tracks is fed with a pulsating direct voltage. In the modified version the positive and negative half-cycles of the alternating voltage are separated with diodes and made independently adjustable. Furthermore, the motors of the car are fitted with a series diode so that two cars can be controlled simultaneously and independently of each other (see figure 2). One car then runs on a positive voltage (in this case car 1) and the other on a negative voltage. For the latter car, however, the polarity of the motor must be changed, or the car will run backwards.

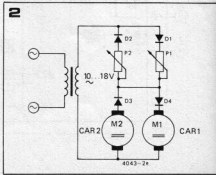
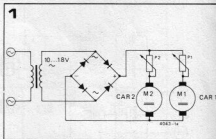

advertisements  
are eye-catching -  
don't you agree?

If you supply electronic components or equipment and would like to advertise in Elektor, please contact us at Canterbury, tel. (0227) 54439 or telex elektor cantbry 965504.

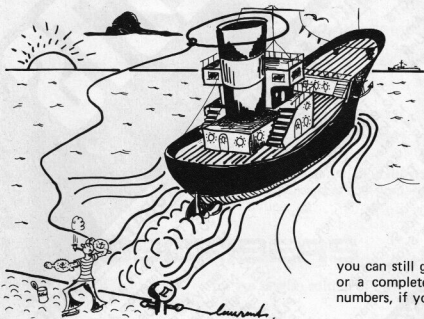

you haven't  
yet missed  
the boat,

you can still get copies of Elektor nos. 1, 2 and 3, or a complete subscription including these back numbers, if you fill in the reply card on page 664.

Our next issue (July/August 1975) will be a double issue, containing over a hundred 'Summer Circuits'.

A few of the projects planned so far are:

elektor  
summer  
circuits



- FM detector
- universal timebase
- 'poor man's' amplifier
- analogue frequency meter
- afterburner
- NAND-NOR gate
- exposomat
- coilless AM receiver
- sawtooth generator
- mostronome
- variable filter
- car service meter
- digital dividers
- staircase generator
- optical doorbell
- function generator
- intercom
- model car brake lights
- lie detector
- active slave flash
- dummy load

Furthermore, there will be descriptions and interesting applications of several new MSI and LSI integrated circuits.



OVER  
25 PROJECTS  
FROM ETI MAGAZINE

# TOP PROJECTS NO.2

REPRINTS OF POPULAR CONSTRUCTIONAL ARTICLES FROM ELECTRONICS TODAY INTERNATIONAL

15p

## AUDIO PROJECTS

1. 50W Stereo Amp
2. Add-on Quad Unit
3. Spring Line Reverb
4. Fumble Filter
5. FET 4—Input Mixer
6. Over—LED

## TEST GEAR

7. I.C. Power Supply
8. Audio Wattmeter
9. Logic Probe

## MOTORISTS

10. Linear IC Tester
11. Trafficator Cancellor
12. Battery Charger
13. Ignition Timing Light
14. Meter Beater
15. Automatic Car Theft Alarm

## FOR THE HOME

16. Printimer
17. Tape/Slide Synchroniser
18. Hi-Power Strobe

(contents may be subject to minor changes before printing)

19. Temperature Alarm
20. LM380 Intercom & Record Player

## MISCELLANEOUS

21. Family Ferry
22. Ni-Cad Battery Charger
23. Digital Stopwatch
24. Earth Resistivity Meter
25. Aerial Matcher

PLUS: SEVERAL PAGES OF  
TECH-TIPS — MANY NOT  
PREVIOUSLY PUBLISHED

AVAILABLE FROM YOUR NEWSAGENTS  
AFTER JUNE 13TH

---Cut---  
---Cut---  
---Cut---

TO: ELECTRONICS TODAY INTERNATIONAL 36 Ebury Street, London SW1W0LW  
Please find enclosed my cheque/P.O. for 90p (including 15p post) for a copy of  
TOP PROJECTS NO.2. To be sent to me as soon as you get copies from  
the printers.

NAME . . . . .  
ADDRESS . . . . .

